



Translation of the Original Operating Manual

VM 5000

Version 08/2014

Electrostatic Control Unit for Electrostatic Manual Spray Guns

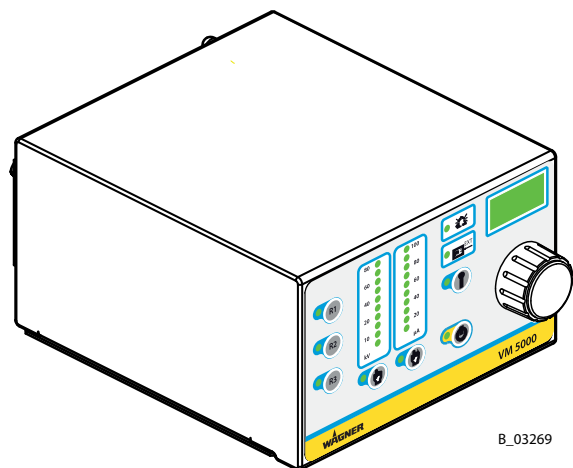

B_03269

CE  II 3 G

Table of Contents

1	ABOUT THIS MANUAL	5
1.1	Preface	5
1.2	Warnings, Notices, and Symbols in this Operating Manual	5
1.3	Languages	6
1.4	Abbreviations in the Text	6
1.5	Terminology for the Purpose of this Manual	7
2	CORRECT USE	8
2.1	Device Type	8
2.2	Type of Use	8
2.3	Use in Potentially Explosive Areas	9
2.4	Safety Parameters	9
2.5	Reasonably Foreseeable Misuse	10
2.6	Residual Risks	10
3	IDENTIFICATION	11
3.1	CE Explosion Protection Identification	11
3.2	Identification "X"	12
3.3	Type Plate	13
4	GENERAL SAFETY INSTRUCTIONS	14
4.1	Safety Instructions for the Operator	14
4.1.1	Electrical Equipment	14
4.1.2	Staff Qualifications	14
4.1.3	Safe Work Environment	14
4.2	Safety Instructions for Staff	15
4.2.1	Safe Handling of WAGNER Spray Devices	15
4.2.2	Grounding the Device	16
4.2.3	Product Hoses	17
4.2.4	Cleaning and Flushing	17
4.2.5	Handling Hazardous Liquids, Lacquers and Paints	18
4.2.6	Touching Hot Surfaces	19
4.3	Protective and Monitoring Equipment	19
4.4	Use in Areas Subject to Explosion Hazards	19
4.4.1	Safety Regulations	19
5	DESCRIPTION	20
5.1	Design	20
5.2	Mode of Operation	20
5.3	Scope of Delivery	20
5.4	Technical Data	21
5.5	Operating Elements and Connections	22
5.5.1	Operating Elements Front Side	22
5.5.2	Connections on the Rear Side	24
6	ASSEMBLY AND COMMISSIONING	25
6.1	Training Assembly/Commissioning Staff	25
6.2	Storage Conditions	25
6.3	Installation Conditions	25
6.4	Additional Components	26
6.5	Location of the Control Unit	27

Table of Contents

6.6	Grounding	28
6.7	Example, AirCoat Spraying System	30
6.8	Verifying a Safe Operational Condition	31
7	OPERATION	32
7.1	Training the Operating Staff	32
7.2	Safety Instructions	32
7.2.1	Emergency Deactivation	33
7.3	Starting Up the Control Unit	33
7.4	Setting and Saving Recipes	34
7.4.1	Setting the High-voltage	35
7.4.2	Setting the Current Limitation	36
7.4.3	Display During Spraying	37
7.5	Standby Mode	38
7.6	Display "Perform service"	39
7.7	Device Configuration	40
7.7.1	Parameter Overview of Level 1 for Users	40
7.7.2	Access to the Device Configuration Mode	43
7.7.3	Setting Example "Parameter C11"	44
7.8	Operating Hours Counter/Service Display	46
7.8.1	Maintenance Counter Set Up and Reading	47
7.9	External Interface	48
8	CLEANING AND MAINTENANCE	50
8.1	Cleaning	50
8.1.1	Cleaning Staff	50
8.1.2	Safety Instructions	50
8.2	Maintenance	52
8.2.1	Maintenance Staff	52
8.2.2	Safety Instructions	52
8.2.3	Safety Checks	53
9	TROUBLESHOOTING AND RECTIFICATION	54
10	REPAIR WORK	56
10.1	Repair Staff	56
10.2	Safety Instructions	56
10.3	Check the Control Unit for Leak-Tightness	56
11	DISPOSAL	57
12	ACCESSORIES	58
13	SPARE PARTS	59
13.1	How Can Spare Parts Be Ordered?	59
13.2	Control unit VM 5000	60
14	WARRANTY AND CONFORMITY DECLARATIONS	62
14.1	Important Notes Regarding Product Liability	62
14.2	Warranty Claim	62
14.3	CE Declaration of Conformity	63
14.4	Notes on National Regulations and Guidelines	64

1 ABOUT THIS MANUAL

1.1 PREFACE

The operating manual contains information about safely operating, maintaining, cleaning and repairing the device.

The operating manual is part of the device and must be available to operating and service staff.



The device may only be operated by trained staff and in compliance with this operating manual. Operating and service staff should be instructed according to the safety instructions.

This equipment can be dangerous if it is not operated according to the instructions in this operating manual.



1.2 WARNINGS, NOTICES, AND SYMBOLS IN THIS OPERATING MANUAL

Warning instructions in this operating manual highlight particular dangers to users and to the device and state measures for avoiding the hazard. These warning instructions fall into the following categories:



Danger - immediate risk of danger.
Non-observance will result in death or serious injury.

	 DANGER
	<p>This notice warns you of a hazard! Possible consequences of not observing the warning instructions. The signal word indicates the hazard level.</p> <p>→ The measures for preventing the danger and its consequences.</p>

Warning - possible imminent danger.
Non-observance may result in death or serious injury.

	 WARNING
	<p>This notice warns you of a hazard! Possible consequences of not observing the warning instructions. The signal word indicates the hazard level.</p> <p>→ The measures for preventing the danger and its consequences.</p>

Caution - a possibly hazardous situation.
Non-observance may result in minor injury.

	 CAUTION
	<p>This notice warns you of a hazard! Possible consequences of not observing the warning instructions. The signal word indicates the hazard level.</p> <p>→ The measures for preventing the danger and its consequences.</p>

Notice - a possibly hazardous situation.
Non-observance may result in damage to property.

NOTICE
<p>This notice warns you of a hazard! Possible consequences of not observing the warning instructions. The signal word indicates the hazard level.</p> <p>→ The measures for preventing the danger and its consequences.</p>

Note - provides information about particular characteristics and how to proceed.

1.3 LANGUAGES

The **VM 5000** operating manual is available in the following languages:

Language	Order No.	Language	Order No.
German	2310484	English	2318718
French	2318719	Italian	2318720
Spanish	2318721		

Additional languages on request or at: www.wagner-group.com

1.4 ABBREVIATIONS IN THE TEXT

Stk	Number of pieces
Pos	Position
K	Marking in the spare parts lists
Order No.	Order number
ET	Spare part
SSt	Stainless steel
2K	Two components
VM	Voltage Module

1.5 TERMINOLOGY FOR THE PURPOSE OF THIS MANUAL

Cleaning	Manual cleaning of devices and device parts with cleaning agents
Flushing	Internal flushing of ink-guiding parts with flushing agent

Staff qualifications

Trained person	Is instructed in the tasks assigned to him/her, the potential dangers associated with improper behavior, as well as the necessary protective devices and measures.
Electrically trained person	Is instructed by an electrician in the tasks assigned to him/her, the potential dangers associated with improper behavior, as well as the necessary protective devices and measures.
Electrician	Can assess the work assigned to him/her and detect possible dangers based on his/her technical training, knowledge and experience, and knowledge of the relevant provisions.
Skilled person In the context of BGI 764	<p>A person who, based on his/her technical training, experience and recent vocational experience, has sufficient technical knowledge in the area of electrostatic coating and is familiar with the relevant and generally accepted rules of technology so that he/she can inspect and assess the status of devices and coating systems based on workplace safety.</p> <p>→ Additional requirements for skilled persons can also be referred to in TRBS 1203 (2010): Expert knowledge in the areas of protection against excessive pressure, electrical hazards, and explosion protection (where applicable).</p>

2 CORRECT USE

2.1 DEVICE TYPE

Control unit for controlling GM 5000EA or GM 5000EAC electrostatic spray guns and the high-voltage Universal cascade.



2.2 TYPE OF USE

WAGNER's electrostatic control unit VM 5000 controls and regulates the high-voltage supply to the GM 5000EA or GM 5000EAC spray guns used to apply liquid coating media and the high-voltage Universal cascade.

The VM 5000 may only be operated together with the above-mentioned manual spray guns or the high-voltage Universal cascade. If the control unit is operated in combination with devices other than the above-mentioned spray guns, the SIRA authorization (type approval) ceases to be valid.

These electrostatic manual spray guns are suitable for spraying liquid products, in particular coating products that follow AirCoat or Airspray techniques. Coating products containing solvents of explosion class II A may be used.

WAGNER forbids any other use!

	 WARNING
	<p>Incorrect use! Risk of injury and damage to the device.</p> <p>→ Only connect original WAGNER GM 5000EA/GM 5000EAC spray guns or die WAGNER high-voltage Universal cascade to the VM 5000 control unit.</p>

2.3 USE IN POTENTIALLY EXPLOSIVE AREAS

The control unit is designed together with the spray gun in accordance with the 94/9/EC (ATEX) directive. The spray gun is suitable for use in potentially explosive areas in zone 1 and the control unit in the zone 2 area.
(See Chapter 3 "Explosion Protection Identification".)



If the Wagner high-voltage Universal cascade is operated in connection with the VM 5000 control unit, the high-voltage cascade cannot be used in an Ex zone. However, the control unit may be still used in the zone 2 area.

The "Restricted breathing" type of explosion protection is only guaranteed if all sealed elements in the control unit are present and undamaged. During operation, all electric connections of the control unit have to be tightly sealed with the corresponding plug connectors or closing elements.

2.4 SAFETY PARAMETERS

WAGNER accepts no liability for any damage arising from non-intended use.

- Use the device only to work with the products recommended by WAGNER.
- Operate only the device as a whole.
- Do not deactivate safety fixtures.
- Use only WAGNER original spare parts and accessories.



The device may only be operated under the following conditions:

- The operating staff must be trained based on this operating manual.
- The safety regulations listed in this operating manual must be observed.
- The operating, maintenance and repair information in this operating manual must be observed.
- The statutory requirements and accident prevention regulation standards in the country of use must be observed.

The control unit may only be operated if all parameters are set and all measurements/safety checks have been carried out correctly.

2.5 REASONABLY FORESEEABLE MISUSE

The forms of misuse listed below may result in physical injury or property damage:

- Use with non-authorized spray guns;
- Coating work pieces which are not grounded;
- Performing unauthorized conversions or modifications to the device;
- Using defective components, spare parts or accessories other than those described in the "Accessories" chapter of this operating manual;
- Working with incorrect settings.

2.6 RESIDUAL RISKS

Residual risks are risks which cannot be ruled out even in the event of correct use.

If necessary, warning and prohibition signs at the relevant points of risk indicate residual risks.

Residual risk	Source	Consequences	Specific measures	Lifecycle phase
Skin contact with lacquers and cleaning agents	Handling of lacquers and cleaning agents	Skin irritations, allergies	Wear protective clothing, observe safety data sheets	Operation, maintenance, disassembly
Lacquer in air outside the defined working area	Lacquering outside the defined working area	Inhalation of substances hazardous to health	Observe work and operation instructions	Operation, maintenance

3 IDENTIFICATION

3.1 CE EXPLOSION PROTECTION IDENTIFICATION

The control unit is designed together with the spray gun in accordance with the 94/9/EC (ATEX) directive. The spray gun is suitable for use in potentially explosive areas in zone 1 and the control unit in the zone 2 area.



VM 5000 control unit

CE ₀₁₀₂ Ex II (2) G SIRA 11 ATEX 5374X
--

CE	European Communities
0102	Notified body: PTB
Ex	Explosion-proof equipment
II	Device class II (not mining)
()	Effective in zone
(2)	Effective in zone 1
G	Ex-atmosphere gas
SIRA 11 ATEX 5374X	Number of type examination certificate
"X":	see chapter 3.2

CE Ex II 3 G Ex nR IIA T4 Gc
--

CE	European Communities
Ex	Explosion-proof equipment
II	Device class II (not mining)
3	Category 3 device (suitable for zone 2)
G	Ex-atmosphere gas
Ex	Electrical device corresponds to ignition protection type
nR	Ignition protection type "Restricted breathing"
IIA	Device class (Gas) IIA
T4	Temperature class T4
Gc	Device protection level Gc

3.2 IDENTIFICATION "X"

Notice

The EC Type Examination Certificate from SIRA can be found in the operating manual for the spray gun. This certificate covers the control unit when used in conjunction with the spray gun.

The manufacturer certifies that the control unit can be used in zone 2.

Cable connections

Only the corresponding cables for the device may be used (see chapter 12 and operating manual for the spray gun).

Permissible Device Combinations

The following spray guns may be connected to the VM 5000 control unit:

- Spray gun GM 5000EA
- Spray gun GM 5000EAC

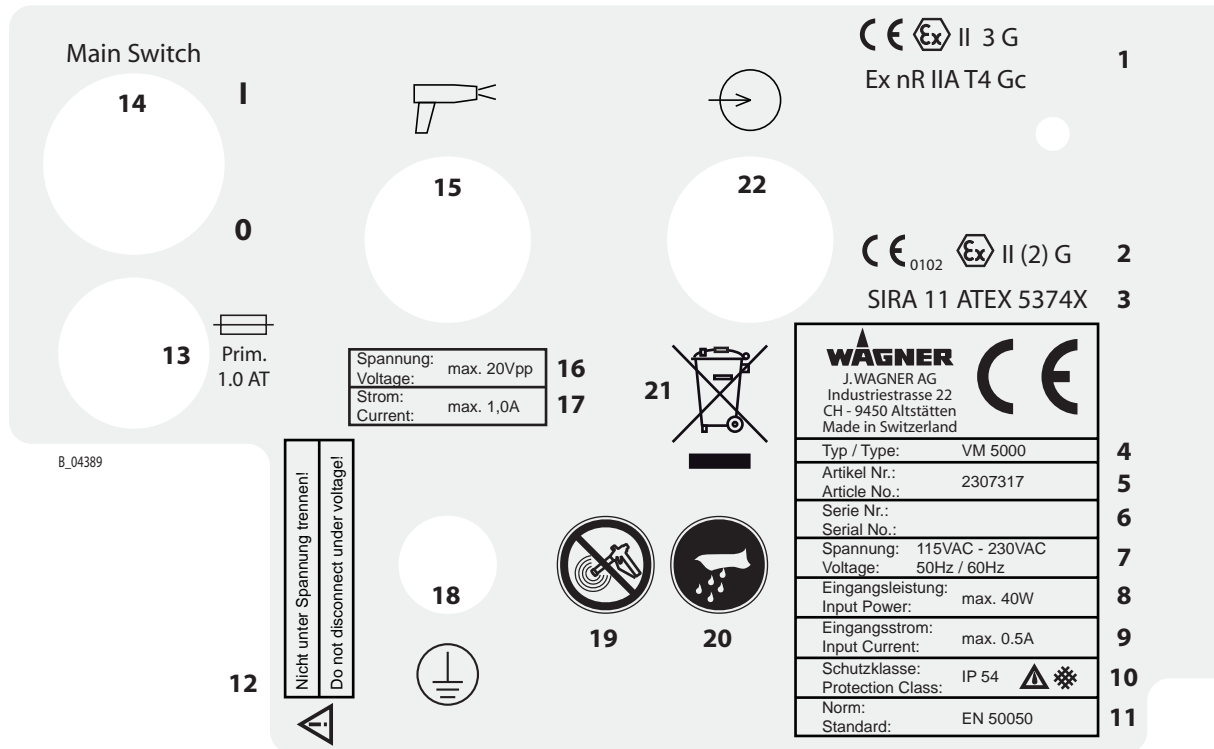
3.3 TYPE PLATE

- | | | | |
|----|--|----|--|
| 1 | Identification for category 3 (zone 2) | 13 | Primary fuse 1.0 ampere slow-acting |
| 2 | Identification for category 2 (zone 1) | 14 | Mains supply switch |
| 3 | Test center | 15 | Gun connection |
| 4 | Device type | 16 | Maximum voltage |
| 5 | Article number | 17 | Maximum current |
| 6 | Serial No. | 18 | Grounding |
| 7 | Input voltage | 19 | Never spray device parts using electrostatic equipment (electrostatic spray gun!). |
| 8 | Input power | 20 | Use only a damp cloth to clean the unit. Remove deposits from the surfaces. |
| 9 | Input current | 21 | Do not dispose of used electrical equipment with household refuse. |
| 10 | Protection class | 22 | Interface |
| 11 | Standard | | |
| 12 | Do not disconnect under voltage! | | |

4 GENERAL SAFETY INSTRUCTIONS

4.1 SAFETY INSTRUCTIONS FOR THE OPERATOR

- Keep this operating manual on hand near the device at all times.
- Always follow local regulations concerning occupational safety and accident prevention.



4.1.1 ELECTRICAL EQUIPMENT

Electrical devices and equipment

- To be provided in accordance with the local safety requirements with regard to the operating mode and ambient influences.
- May only be maintained by skilled electricians or under their supervision. With open housings, there is a danger from line voltage.
- Must be operated in accordance with the safety regulations and electrotechnical regulations.
- Must be repaired immediately in the event of problems.
- Must be decommissioned if they pose a hazard or are damaged.
- Must be de-energized before work is commenced on active parts. Inform staff about planned work. Observe electrical safety regulations.
- Connect all devices to a common grounding point.
- Only operate the device with a properly installed socket with a protective ground wire connection.
- Keep liquids away from electrical devices.



4.1.2 STAFF QUALIFICATIONS

- Ensure that the device is operated, maintained and repaired only by trained staff.

4.1.3 SAFE WORK ENVIRONMENT

- Ensure that the floor in the working area is static dissipative in accordance with EN 61340-4-1 (resistance must not exceed 100 megohms).
- Ensure that all persons within the working area wear static dissipative shoes. Footwear must comply with EN 20344. The measured insulation resistance must not exceed 100 megohms.
- Ensure that during spraying, persons wear static dissipative gloves. Grounding takes place via the spray gun handle.
- If protective clothing is worn, including gloves, it has to comply with EN 1149-5. The measured insulation resistance must not exceed 100 megohms.
- Paint mist extraction systems/ventilation systems must be fitted on site according to local regulations.

- Ensure that the following components of a safe working environment are available:
 - Product/air hoses adapted to the working pressure.
 - Personal safety equipment (breathing and skin protection).
- Ensure that there are no ignition sources such as naked flames, sparks, glowing wires, or hot surfaces in the vicinity. Do not smoke.
- Ensure that the pipe joints, hoses, equipment parts and connections are permanently, technically leak-proof:
 - Periodic preventative maintenance and service (replacing hoses, checking tightness of connections, etc.).
 - Regular monitoring of leaks and defects via visual inspection and odor testing, e.g., daily before commissioning, at the end of work or weekly.
- In the event of defects, immediately bring the device or system to a stop and arrange to have repairs carried out immediately.



4.2 SAFETY INSTRUCTIONS FOR STAFF

- Always follow the information in this manual, particularly the general safety instructions and the warning instructions.
- Always follow local regulations concerning occupational safety and accident prevention.
- Anyone fitted with a pacemaker must not enter the high-voltage area!



4.2.1 SAFE HANDLING OF WAGNER SPRAY DEVICES

The spray jet is under pressure and can cause dangerous injuries.

Avoid injection of paint or flushing agents:

- Never point the spray gun at people.
- Never reach into the spray jet.
- Before all work on the device, in the event of work interruptions and functional faults:
 - Switch off the energy/compressed air supply.
 - Relieve the pressure from the spray gun and device.
 - Secure the spray gun to prevent actuation.
 - In the event of functional faults, remedy the fault as described in the "Troubleshooting" chapter.
- If necessary, or at least every 12 months, the liquid ejection devices should be checked by an expert (e.g. Wagner service technician) to ensure their safe operational condition in accordance with the guidelines for liquid ejection devices (ZH 1/406 and BGR 500 Part 2 Chapter 2.29 and 2.36).
 - If devices have been decommissioned, the examination can be suspended until the next start-up.



- Carry out the work steps as described in the "Pressure Relief" chapter:
- If pressure relief is required.
 - If the spraying work is interrupted or stopped.
 - Before the device is cleaned on the outside, checked or serviced.
 - Before the spray nozzle is installed or cleaned.

In the event of skin injuries caused by paint or flushing agents:

- Note the paint or flushing agent that you have been using.
→ Consult a doctor immediately.

Avoid risk of injury from recoil forces:

- Ensure that you have firm footing when operating the spray gun.
→ Only hold the spray gun briefly in a position.

4.2.2 GROUNDING THE DEVICE

Friction, flowing liquids, and air or electrostatic coating processes create charges. Flames or sparks can form during discharge. Grounding prevents electrostatic charging.

- Ensure that the device is grounded. → See chapter "Grounding".
→ Ground the work pieces to be coated.
→ Ensure that all persons inside the working area are grounded, e.g., that they are wearing static dissipative shoes.
→ Wear static dissipative gloves when spraying. Grounding takes place via the spray gun handle.
→ The spray substance supply (spray substance tank, pump, etc.) must be grounded.



4.2.3 PRODUCT HOSES

- Ensure that the hose material is chemically resistant to the sprayed products and the flushing agents used.
- Ensure that the product hose is suitable for the pressure generated.
- Ensure that the following information can be seen on the high-pressure hose:
 - Manufacturer
 - Permissible operating pressure
 - Date of manufacture
- Make sure that the hoses are laid only in suitable places. Hoses should not be laid in the following places under any circumstances:
 - In high-traffic areas
 - At sharp edges
 - On moving parts
 - On hot surfaces
- Ensure that the hoses are never run over by vehicles (e.g. fork lifts), or that the hoses are never put under pressure from the outside in any other way.
- Ensure that the hoses are never kinked. Observe maximum bending radii.
- Make sure that the hoses are never used to pull or move the device.
- Suction hoses may not be subjected to pressure.



Several liquids have a high expansion coefficient. In some cases, their volume can rise with consequent damage to tubes, fittings, etc. and cause fluid leakage.

When the pump sucks liquid from a closed tank, ensure that air or a suitable gas can enter the tank. Thus a negative pressure is avoided. The vacuum could implode the tank (squeeze) and can cause it to break. The tank would leak and the liquid would flow out. The pressure created by the pump is a multiplication of the inlet air pressure.

4.2.4 CLEANING AND FLUSHING

- Relieve the pressure from the device.
- De-energize the device electrically.
- Preference should be given to non-flammable cleaning and flushing agents.
- Observe the specifications of the paint manufacturer.
- Ensure that the flash point of the cleaning agent is at least 15 K above the ambient temperature or that cleaning is undertaken at a cleaning station with technical ventilation.
- Take measures for workplace safety (see Chapter 4.1.3).

- When commissioning or emptying the device, please note that an explosive mixture may temporarily exist inside the lines and components of equipment:
 - depending on the coating product used,
 - depending on the flushing agent (solvent) used,
 explosive mixture inside the lines and items of equipment.
- Only electrically conductive tanks may be used for cleaning and flushing agents.
- The tanks must be grounded.



An explosive gas/air mixture forms in closed tanks.

- Never spray into a closed tank when using solvents for flushing.

External cleaning

When cleaning the exterior of the device or its parts, also observe the following:

- Disconnect the pneumatic supply line.
- Use only moistened cloths and brushes. Never use abrasive agents or hard objects and never spray cleaning agents with a gun. Cleaning the device must not damage it in any way.
- Ensure that no electrical component is cleaned with nor even immersed into solvent.
- Which cleaning agent is used to clean the spray gun depends on which parts of the spray gun have to be cleaned and which product has to be removed. When cleaning the spray gun, only use **non-polar cleaning agents** to prevent conductive residues on the surface of the spray gun. Should it however, be necessary to use a polar cleaning agent, all residues of this cleaning agent have to be removed by using a non-conductive and non-polar cleaning agent, once the cleaning is finished.

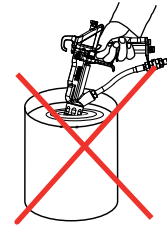

4.2.5 HANDLING HAZARDOUS LIQUIDS, LACQUERS AND PAINTS

- When preparing or working with lacquer and when cleaning the device, follow the working instructions of the manufacturer of the lacquers, solvents and cleaning agents being used.
- Take the specified protective measures, in particular wear safety goggles, protective clothing and gloves, as well as skin protection cream if necessary.
- Use a mask or breathing apparatus if necessary.
- For sufficient health and environmental safety: operate the device in a spray booth or on a spraying wall with the ventilation (extraction) switched on.
- Wear suitable protective clothing when working with hot products.



4.2.6 TOUCHING HOT SURFACES

- Only touch hot surfaces if you are wearing protective gloves.
- When operating the device with a coating product with a temperature of > 43 °C; 109 °F:
 - Identify the device with a warning label, "Warning – Hot surface".

Order No.

9998910	Instruction label
9998911	Protection label

Note: Order the two labels together.



4.3 PROTECTIVE AND MONITORING EQUIPMENT

- Protective and monitoring equipment must not be removed, modified or rendered unusable.
- Regularly check for perfect functioning.
- If defects are detected on protective and monitoring equipment, the system must not be operated until these defects are remedied.

4.4 USE IN AREAS SUBJECT TO EXPLOSION HAZARDS

The control unit may be used in potentially explosive areas. The following safety regulations must be observed and followed.



4.4.1 SAFETY REGULATIONS

- Observe safety instructions in Chapter 3.2.

Surface spraying, electrostatics

- Never spray device parts using electrostatic equipment (electrostatic spray gun!).



Cleaning

If there are deposits on the surfaces, the device may form electrostatic charges. Flames or sparks can form during discharge.

- Remove deposits from the surfaces to maintain conductivity.
- Only use a damp cloth to clean the device.



5 DESCRIPTION

5.1 DESIGN

The VM 5000 control unit, together with the matching GM 5000EA or GM 5000EAC spray gun and other components, form an electrostatic manual spray system. An example of this kind of spraying system can be found in Chapter 6.7.

5.2 MODE OF OPERATION

The VM 5000 control unit supplies the control voltage for the spray gun, in which high-voltage is subsequently produced. The set value for high-voltage and the spray current limitation are adjusted on the control unit and can be saved in three different recipes. The high-voltage supply is switched on and off via the trigger of the spray gun.

The special linear characteristic for high voltage ensures that if the spray gun is brought too close to the work piece (or ground), the high voltage is reduced automatically to prevent an accidental spark discharge.

Additionally, the VM 5000 control unit can be used as a universal high-voltage generator, in combination with the high-voltage Universal cascade.

In addition, the VM 5000 control unit has a wide range of other functions, such as an operating hours counter, service interval display, external approval, fault display and an easy-to-use interface.

5.3 SCOPE OF DELIVERY

Quantity	Order No.	Description
1	2310477	VM 5000 control unit

The standard equipment includes:

Quantity	Order No.	Description
1	241270	Mains cable with Stak200; 3 m; 9.8 ft
1	130215	Grounding cable 10 m; 32.8 ft
2	9951117	Delay-action fuse 1.0 AT
1	2310487	ES 5000 Declaration of Conformity, manual
1	2310484	VM 5000 operating manual, German
1	see 1.1	Operating manual in local language

The delivery note shows the exact scope of delivery.

5.4 TECHNICAL DATA

Input voltage	115 VAC - 230 VAC, 50 Hz / 60 Hz
Input power	max. 40 W
Input current	max. 0.5 A
Output voltage	max. 20 Vpp
Output current	max. 1.0 A AC
High-voltage limiting	80 kV DC
Spray current limitation	100 μ A DC
Polarity	for negative high-voltage generators
Protection class	IP 54 *
Weight (without cables)	2.3 kg; 5.07 lb
Operating temperature range	0 °C – 40 °C; 32 °F – 104 °F

* Splash water protection is only guaranteed when the gun cable socket is screwed to the device plug and the mains cable plug is fixed to the control unit plug with the safety clip.

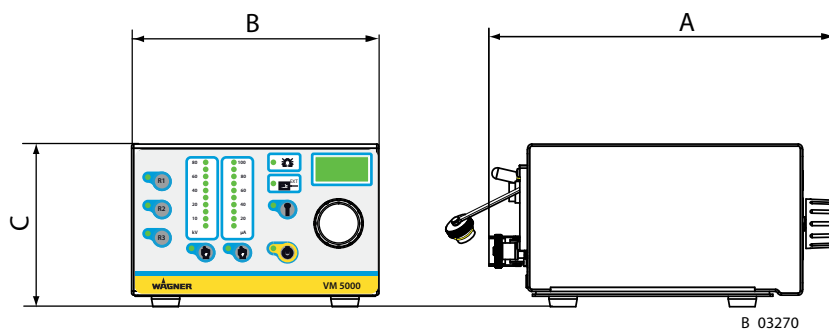
Dimensions

VM 5000		
	mm	inch
A	250	9.84
B	180	7.09
C	120	4.72

5.5 OPERATING ELEMENTS AND CONNECTIONS

5.5.1 OPERATING ELEMENTS FRONT SIDE

- 1 Push button "Recipe 1"**
- 2 Push button "Recipe 2"**
- 3 Push button "Recipe 3"**
- 4 Illuminated display "R1"**
Lights up if recipe 1 is used.
- 5 Illuminated display "R2"**
Lights up if recipe 2 is used.
- 6 Illuminated display "R3"**
Lights up if recipe 3 is used.
- 7 Declaration of values for high-voltage in kV**
- 8 Illuminated display: "High-voltage"**
 - Lights up green
 - Display range: 0-80 kV
 - Single LED display: Nominal voltage
 - Bar display: Working voltage
- 9 Illuminated display "Spray current"**
 - Lights up green
 - Display range: 0-100 μ A
 - Single LED display: "Spray Current Limitation"
 - Bar display: Actual spray current
- 10 Declaration of values for spray current in μ A**
- 11 Illuminated display "External release"**
 - Lights up, if Parameter C11 is set
 - Blinks if the spray gun trigger is pulled, without external approval, while Parameter C11 is set
- 12 Illuminated display "Fault"**
- 13 Illuminated display "Service"**
- 14 Push button "Service"**

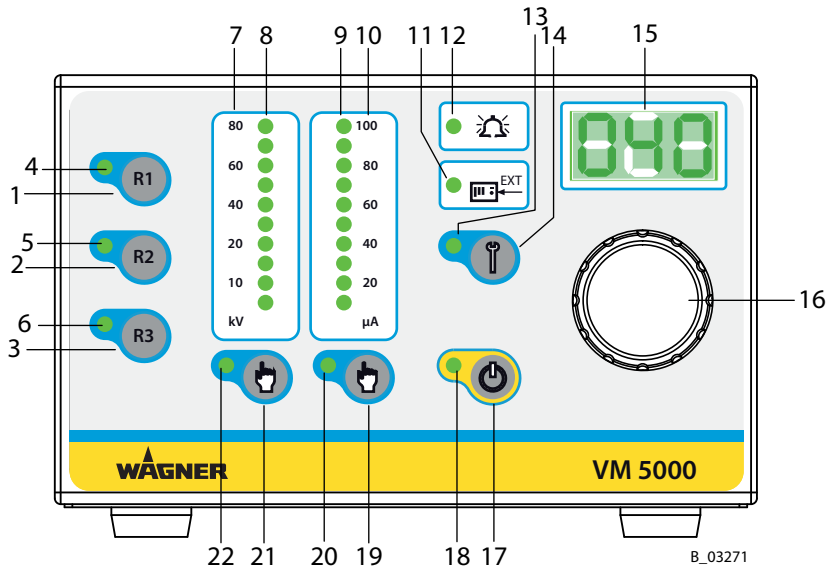
**15 LED display: 7 segments, three-digit number**

- Displays set values and actual values for high-voltage and for the spray current
- Display showing error number in the event of warnings and malfunctions

16 Universal control dial

- Dynamic digital control dial with 32 positions per revolution
- Adjustment speed is proportional to rotational speed
- Used to adjust high-voltage and spray current
- For setting parameter values in configuration mode

17 Push button: "Standby Mode"**18 Illuminated display Standby****19 Push button "Spray current"**

- To activate the function, the current limitation is set with the control dial (16) and is indicated in the LED display 9
- Adjusting range: 5-100 μA
- Resolution: 1 μA

20 Illuminated display "Spray current"**21 Push button: "High-voltage"**

- To activate the function, the high-voltage is set with the control dial (16) and is indicated in the LED display 8
- Adjusting range: 5 to 80 kV
- Resolution: 1 kV

22 Illuminated display: "High-voltage"

5.5.2 CONNECTIONS ON THE REAR SIDE

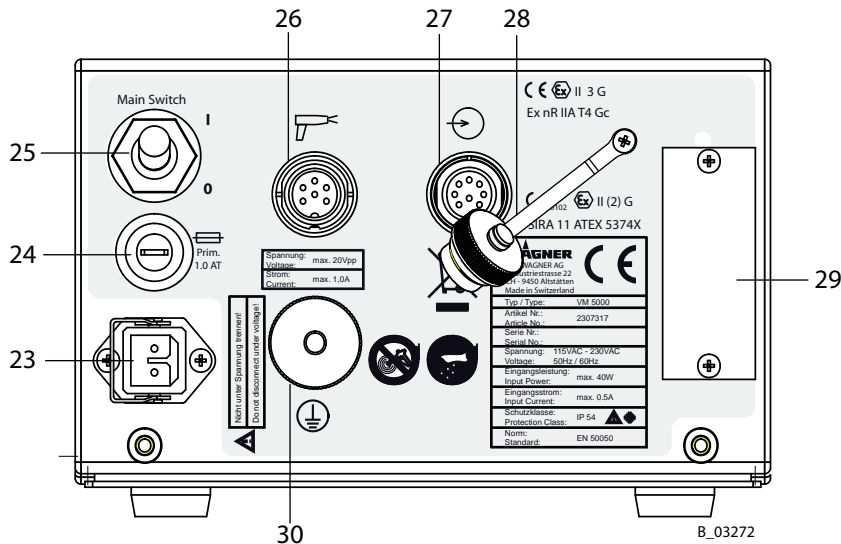

23 Mains input terminal

Connection for mains cable with safety clip
Warning - Do not disconnect under voltage.

24 Primary fuse

1.0 ampere slow-acting

25 Mains supply switch

0 = The control unit is deactivated

1 = The control unit is activated

26 Gun connection

To connect a GM 5000EA or GM 5000EAC gun

When operating with high-voltage Universal cascade → high-voltage Universal cascade connection

Warning - Do not disconnect under voltage.

27 Interface

Warning - Do not disconnect under voltage.

28 Cover of the interface connection

29 Cover of the service connection



Only for WAGNER service personnel

30 Knurled nut grounding

Grounding cable connection to the signal ground

6 ASSEMBLY AND COMMISSIONING

6.1 TRAINING ASSEMBLY/COMMISSIONING STAFF

	 WARNING
	<p>Incorrect installation/operation! Risk of injury and damage to the device.</p> <ul style="list-style-type: none"> → The assembly and commissioning staff must have the technical skills to safely undertake commissioning. → When assembling, commissioning and carrying out all work, read and follow the operating manuals and safety regulations for the additionally required system components.

- Do not open the control unit.
- Observe safety instructions in Chapter 4.

A skilled person must check to ensure that the device is in a reliable state after it is installed and commissioned.

6.2 STORAGE CONDITIONS

Until the point of assembly, the device must be stored in a dry location, free of vibrations and with a minimum amount of dust. The device must be stored in enclosed rooms.

The air temperature at the storage location must be between -20 °C and +60 °C (-4 °F and +140 °F).

The relative air humidity at the storage location must be between 10 and 95% (without condensation).

6.3 INSTALLATION CONDITIONS

The air temperature at the installation site must be in a range between 0 °C and 40 °C; 32 and 132 °F.

The relative air humidity at the installation site must be between 10 and 95% (without condensation).

6.4 ADDITIONAL COMPONENTS

This control unit can be used to complete an electrostatic manual spray system. To do so, a suitable spray gun and the relevant components for the selected spray process are required (see WAGNER accessories).

Spray guns that are compatible with the VM 5000:

Air-Spray GM 5000EAR or GM 5000EAF

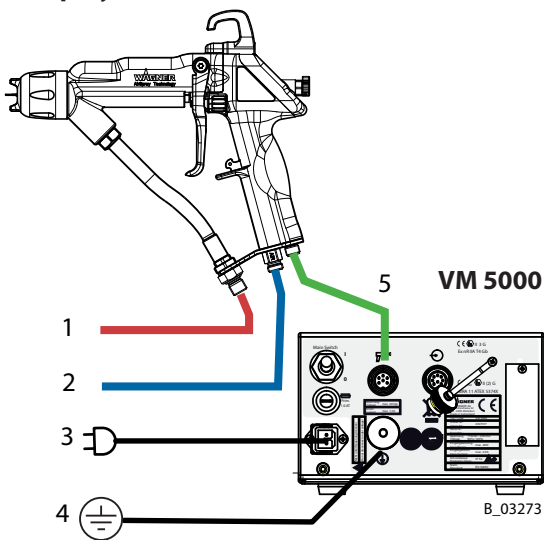

AirCoat-Spray GM 5000EACR or GM 5000EACF

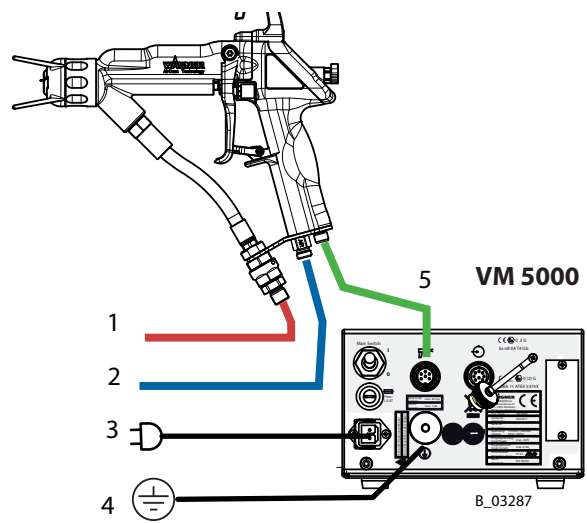

1	for the product supply system	3	Mains cable	5	Gun cable
2	for the compressed air supply	4	Grounding cable to the signal ground		

The operation of the VM 5000 in combination with the high-voltage Universal cascade is described in detail in the operating manual of the high-voltage Universal cascade.

	<p>! WARNING</p>
	<p>Incorrect installation/operation! Risk of injury and damage to the device.</p> <p>→ When commissioning and for all work, read and follow the operating manual and safety regulations for the additionally required system components.</p>

NOTICE

Impurities in the spraying system!

Spray gun blockage, products harden in the spraying system.

→ Flush the spray gun and paint supply with a suitable flushing agent.

6.5 LOCATION OF THE CONTROL UNIT



DANGER

Incorrect installation of the device!

Explosion hazard and damage to the device.

- Set up the device outside the spray booth / spray zone.
- If possible, set up the device outside the Ex zone (Ex zone 2 is permissible).
- Protect the device from significant temperature and moisture changes.
- Protect the device from contamination.
- Lay and fix the connecting cable correctly.
- Ensure that the local mains voltage and tension of the device match.

All sealed elements on the control unit must be present and undamaged. During operation, all electric connections of the control unit have to be tightly sealed with the corresponding plug connectors or closing elements. While under voltage, neither plug connectors nor closing elements may be separated or opened.



WARNING



Sparks form when live components are separated or connected!



Explosion hazard from electric sparks.

- Do not disconnect plug connections under voltage.
- Do not open fuse holders under voltage.
- Do not remove the service plug cover under voltage.

6.6 GROUNDING

It is important for systems safety and to achieve an optimum coating that all system components such as work pieces, conveyors, paint supply, control unit and booth or spraying stand are perfectly grounded.

	 WARNING
	<p>Discharge of electrostatically charged components in atmospheres containing solvents! Explosion hazard from electrostatic sparks or flames.</p> <p>→ Ground all device components. → Ground the work pieces to be coated.</p>

	 WARNING
	<p>Heavy paint mist if grounding is insufficient! Danger of poisoning. Insufficient paint application quality.</p> <p>→ Ground all device components. → Ground the work pieces to be coated.</p>

A poorly grounded work piece causes:

- very bad wrap around,
- uneven coating,
- back spraying to the spray gun (contamination) and coater.

Prerequisites for perfect grounding and coating are:

- Clean work piece suspension.
- Grounding of spray booth, conveyor system and suspension on the building side in accordance with the operating manuals or the manufacturer's information.
- Grounding of all conductive parts within the working area.
- The grounding resistance of the work piece must not exceed 1 MΩ (megohm). (Ground leakage resistance measured at 500 V or 1,000 V)
- Connect the control unit to the signal ground.
- Connect all ground cables using a short and direct route.
- Safety shoes and gloves, if used, must be static dissipative.

Grounding scheme (example)

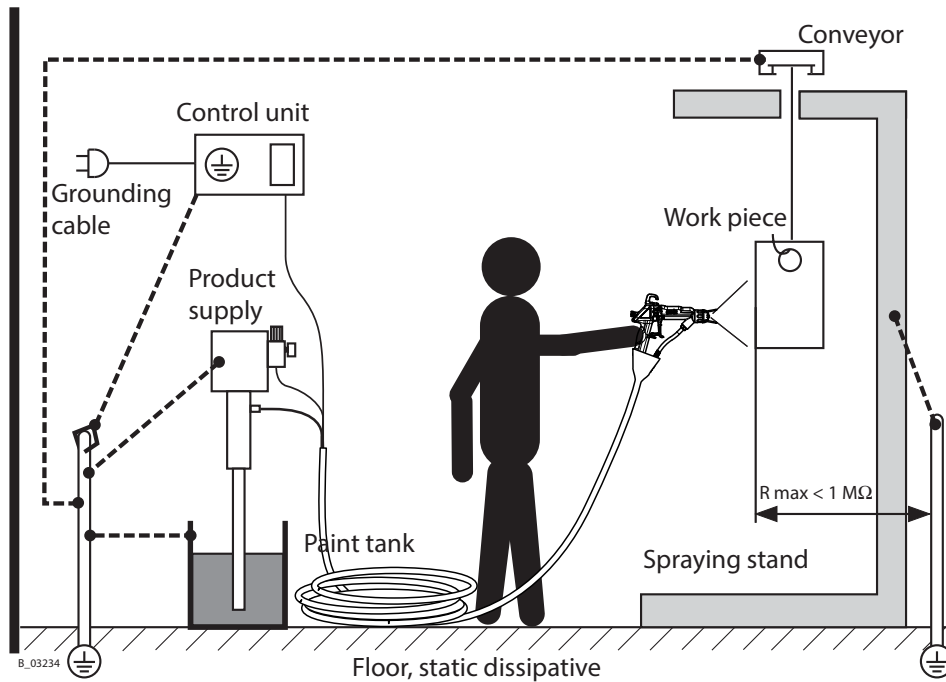

Minimum cable cross-section

Control unit	4 mm ² / AWG 12
Product supply	
Paint tank	
Conveyor	16 mm ² / AWG 6
Booth	
Spraying stand	

Grounding of spray gun

The spray gun is grounded via the spray gun cable.

→ The spray gun GM 5000EA or GM 5000EAC must be connected to the control unit VM 5000 via the spray gun cable.

Note for the sprayer

Safety shoes and gloves, if used, must be static dissipative.

6.7 EXAMPLE, AIRCOAT SPRAYING SYSTEM

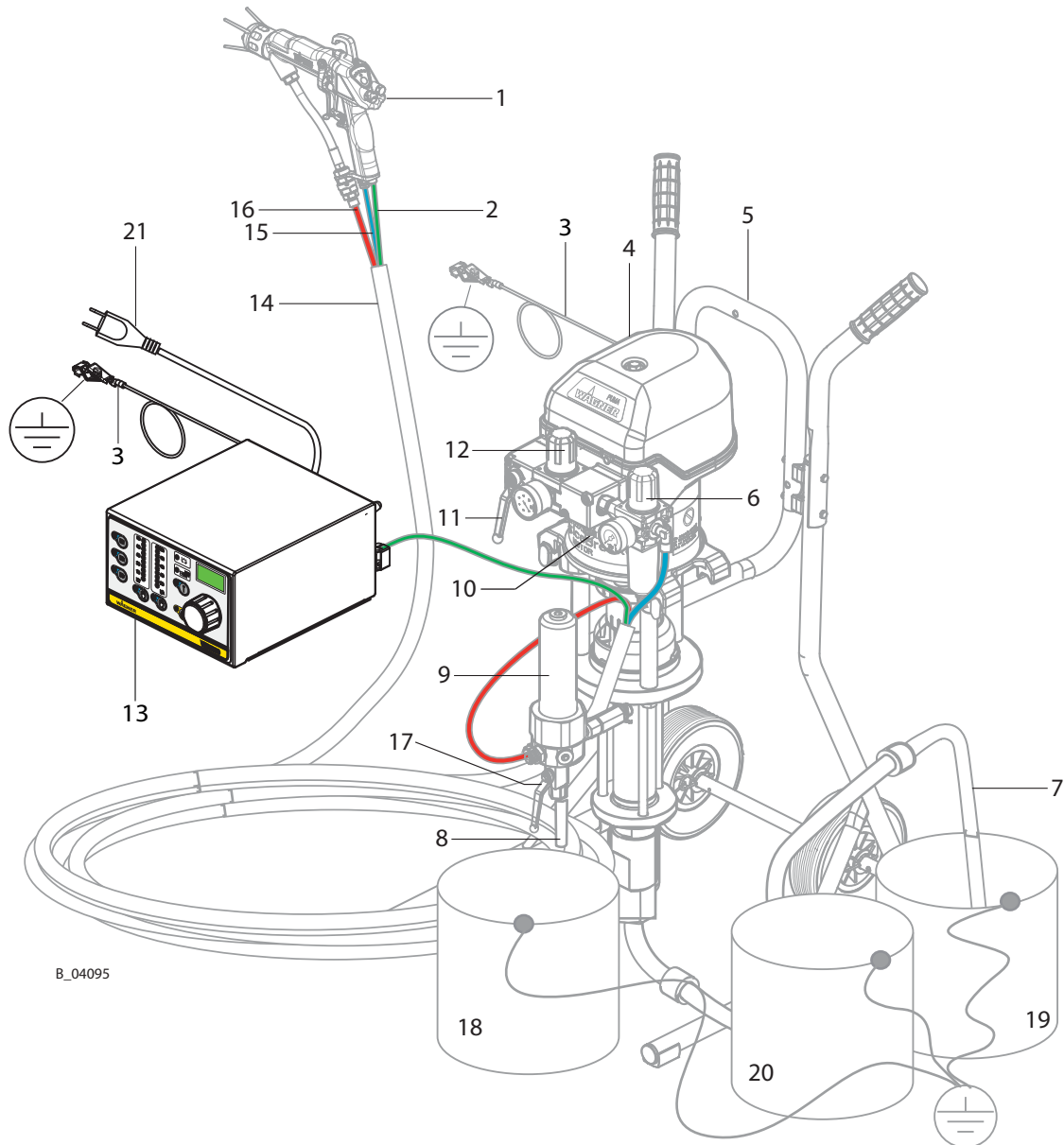

B_04095

Pos	Description
1	Spray gun GM 5000EACF
2	Gun cable
3	Grounding cable
4	Pneumatic pump
5	Sliding table
6	Air pressure regulator + air filter
7	Product suction system

Pos	Description
8	Return hose
9	High-pressure filter
10	Compressed air connection
11	Stop valve
12	Air pressure regulator
13	VM 5000 control unit
14	Protective hose

Pos	Description
15	Air hose
16	Product hose
17	Return valve
18	Tank for return flow
19	Paint tank
20	Tank for flushing agent
21	Mains cable

The following points should be noted before commissioning:

- Lay grounding cable from the grounding screw on the device to the signal ground and ensure that all other conductive parts within the working area are grounded.
- Connect the VM 5000 electrostatic control unit via the mains cable to the socket interlocked with the extraction system.
- Connect the gun cable to the connector socket and screw into place.
- Connect the spray gun to the adjustable, clean air supply.
For compressed air quality, see operating manual for spray gun.
- Connect the GM 5000EA or GM 5000EAC to the paint supply as described in the relevant operating manuals.
- Check that all product-conveying connections are correctly connected.
- Check that all air-conveying connections are correctly connected.
- Visually check the permissible pressures for all the system components.
- Check the level of the separating agent in the pump and fill up if necessary.
- Provide product tank, tanks for flushing agent and an empty tank for return flow.
- The interface on the rear of the control unit must be protected with a cover.
- Connect the system to the air supply.
- When first commissioning the unit → Flush the system in accordance with the operating manuals for the other components.

Configuring the Control Unit

- see Chapter 7.7



6.8 VERIFYING A SAFE OPERATIONAL CONDITION

A skilled person must check to ensure that the device and the spraying system are in a safe state after they are installed and commissioned.





7 OPERATION



7.1 TRAINING THE OPERATING STAFF

	 WARNING
	<p>Incorrect operation! Risk of injury and damage to the device.</p> <ul style="list-style-type: none"> → The operating staff must be qualified and fit to operate the entire system. → The operating staff must be familiar with the potential risks associated with improper behavior as well as the necessary protective devices and measures. → Before work commences, the operating staff must receive appropriate system training.

7.2 SAFETY INSTRUCTIONS

- Do not open the control unit.
- Observe safety instructions in Chapter 4.

	 WARNING
	<p>Incorrect operation! Risk of injury and damage to the device.</p> <ul style="list-style-type: none"> → If contact with lacquers or cleaning agents causes skin irritation, appropriate precautionary measures must be taken, e.g. wearing protective clothing. → The footwear worn by operating staff must comply with EN ISO 20344. The measured insulation resistance must not exceed 100 megohms. → The protective clothing, including gloves, must comply with EN ISO 1149-5. The measured insulation resistance must not exceed 100 megohms.

	 WARNING
	<p>Discharge of electrostatically charged components in atmospheres containing solvents! Explosion hazard from electrostatic spark-over.</p> <ul style="list-style-type: none"> → Use gun only with fitted nozzle, air cap and union nut.





DANGER

High-voltage field!
 Danger to life from malfunction of heart pacemaker

Make sure that persons with pacemakers:
 → Do not work with the electrostatic spray gun.
 → Do not enter the high-voltage area.

7.2.1 EMERGENCY DEACTIVATION

In the case of unforeseen occurrences, proceed as follows:

1. Switch off control unit.
2. Close the compressed air supply.
3. Relieve pressure according to the operating manual of the product pressure generator.
4. Point the spray gun toward the grounded collecting tray.
5. Pull the trigger of the spray gun until no further pressure is present.

7.3 STARTING UP THE CONTROL UNIT

1. Set main switch to position I.

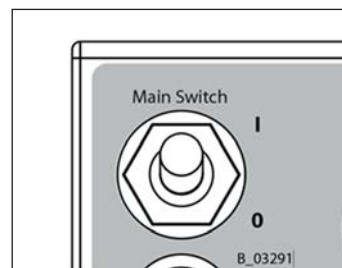

2. For approx. 1 second all LEDs light up
 → Display test

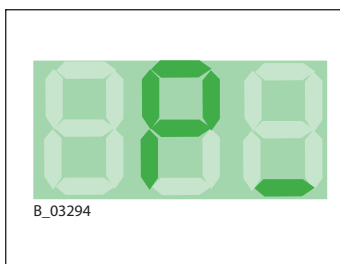
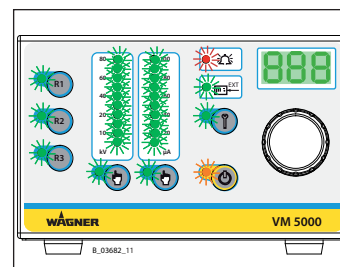

3. The hardware and software versions are briefly shown, one after the other, on the display.

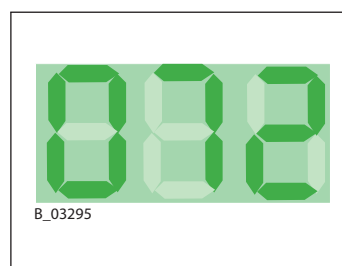

4. The control unit is ready for operation.

Note:

Each starting sequence is concluded by allocating the saved set data in recipe "R1".

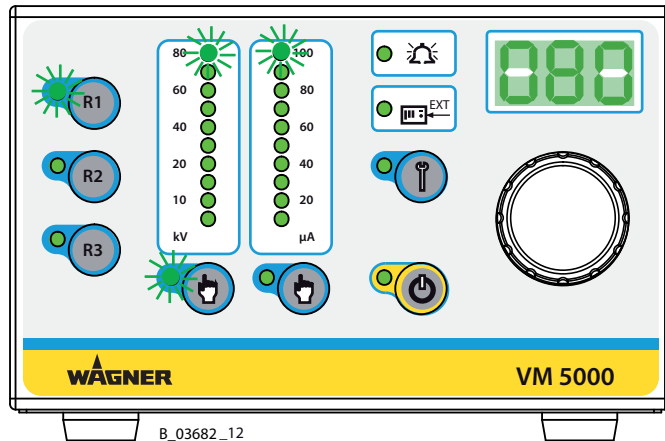

7.4 SETTING AND SAVING RECIPES

Set values for the high-voltage (kV) and for the spray current limitation (μA) are stored in a recipe. By default, the following values are saved at the factory in the 3 storage places available for recipes:

Recipe No.	Set value - high-voltage in kV	Set value - spray current limitation in μA
R1	80	100
R2	60	100
R3	40	80

Recipes 1-3 can be selected and saved directly with the program buttons "R1", "R2" and "R3". Once the recipe required has been called up, the individual coating parameters can be called up and modified with the corresponding selection buttons (see Chapter 7.4.1 and 7.4.2). When a parameter is changed, the LED on the left of the program button goes out and indicates to the user that a parameter value has been changed.

The process for saving parameters is described below.

- To reuse the originally set values, press the program button briefly.
The modified values are not taken over.
- However if the modified values should be saved, press and hold the corresponding program button for approx. 2 seconds, until the LED beside the button starts to flash quickly.
The modified values are then saved.

7.4.1 SETTING THE HIGH-VOLTAGE

Procedure:

1. Press the "High-voltage" button (21) to adjust the high-voltage. The LED (22) indicates that high-voltage is selected.

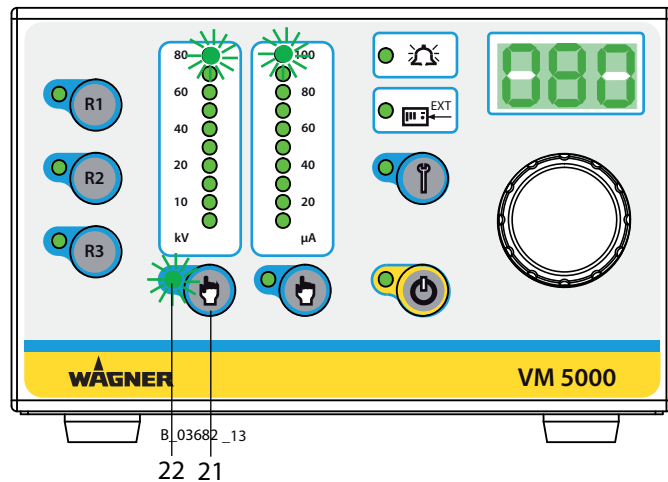

2. The high-voltage can now be adjusted with the universal control dial (16) between the 5 to 80 kV with a resolution of 1 kV. The corresponding value is indicated in the LED display (15).

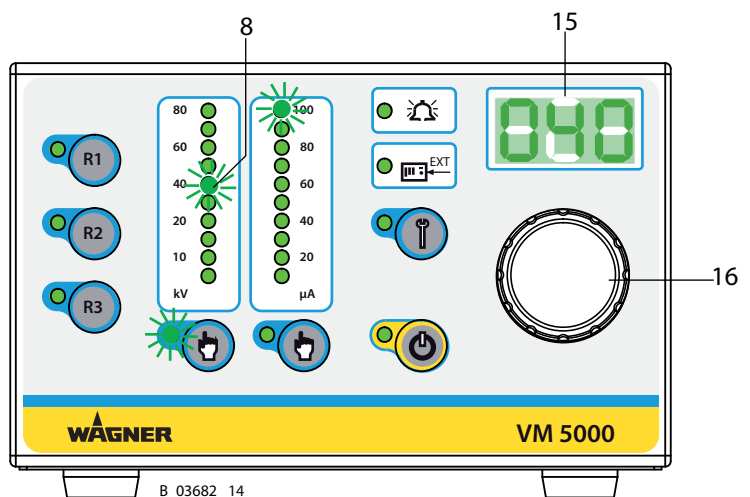

The "High-voltage" bar graph display (8) is located above the "High-voltage" button (21). If the control unit is in the ready position, this light strip shows the set value as a dot.

7.4.2 SETTING THE CURRENT LIMITATION

Procedure:

1. Press the "Current Limitation" button (19) to adjust the limitation of the spray current.
The LED (20) indicates that current limitation is selected.

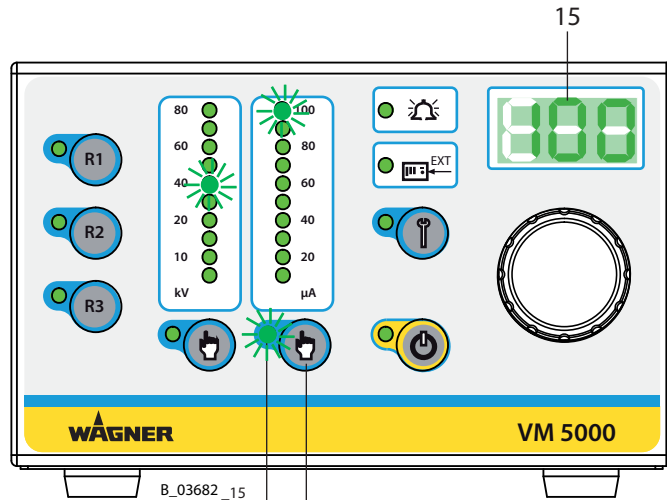

2. The current limitation can now be adjusted with the universal control dial (16) between 10 - 100 μA with a resolution of 1 μA .
The corresponding value is indicated in the LED display (15).

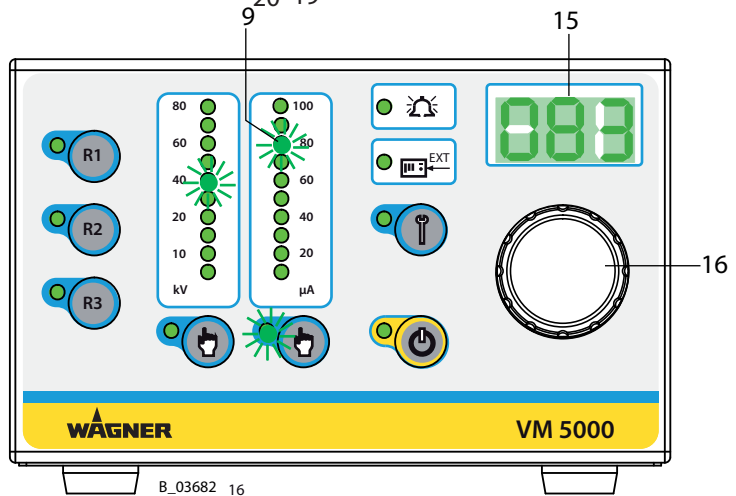

The "Current Limitation" bar graph display (9) is located above the "Current Limitation" push button (19). If the control unit is in the ready position, this light strip shows the set value as a dot.

The current limitation is an adjustable threshold. If this threshold is exceeded, for example, by the spray gun having approached the object being sprayed, the high-voltage is adjusted downwards until the threshold is no longer exceeded.

The set values for high-voltage (40 kV) and for spray current limitation (83 mA) that are shown in the examples, are saved in R2 by pressing and holding for a longer time the recipe push button (for > 2 seconds).

7.4.3 DISPLAY DURING SPRAYING

Ready to spray using R2 recipe. See figure below.

Control unit in ready position.

The LEDs for the set values light up in a dot arrangement and the value for high-voltage is displayed in digits. If you press the push button for current limitation, the adjusted set value for the spray current limitation is displayed in digits.

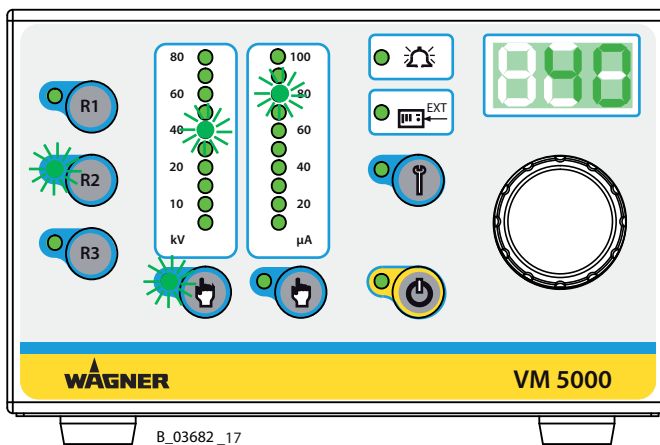

Spraying using recipe R2.

By actuating the trigger on the spray gun, high voltage is produced. The LEDs light up in a bar and display the actual values. The current actual value for the activated push button for high-voltage (kV) is displayed in digits. If the push button for the spray current limitation is pressed, the respective LED lights up and the respective actual value appears in μA .

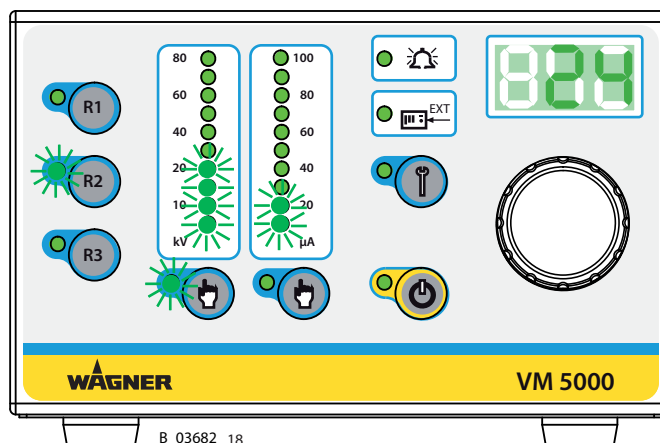

7.5 STANDBY MODE

If you want to spray without high-voltage, select the standby mode. Press push button (17) briefly and the "Standby" illuminated display (18) lights up. All the other LEDs go out.

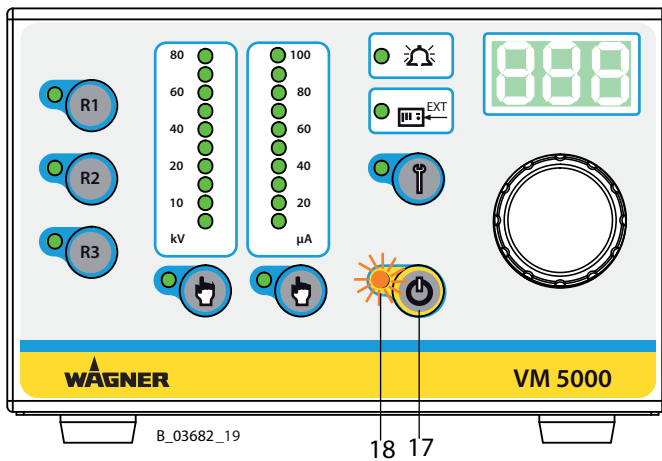

The previously saved standby mode can be accessed from standby mode by pressing the push button (17) again. See figure below.

Note:
This function can be activated and used from the gun.

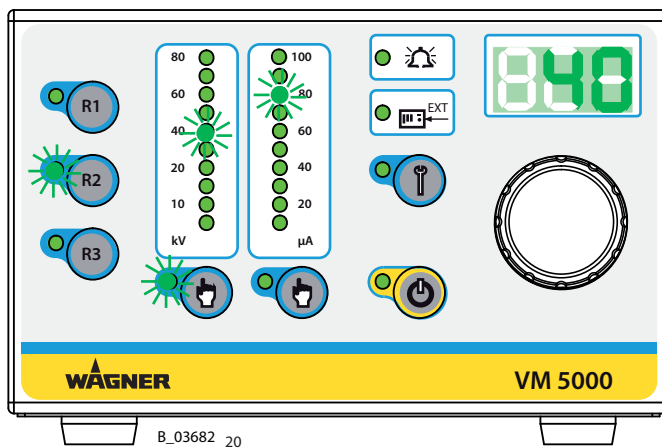

7.6 DISPLAY "PERFORM SERVICE"

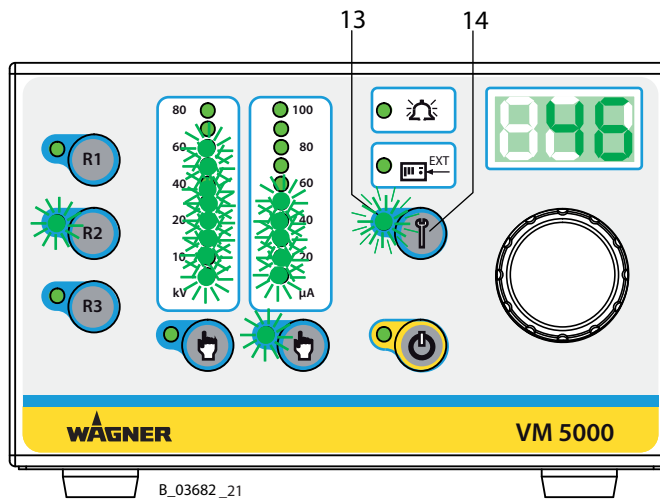

Prerequisite:

The function "Maintenance interval limit" is activated.

"Servicing the spray gun"

Once the time for the defined maintenance interval has expired, the LED display (13) starts to flash.

The flashing service display merely acts as a warning. You can continue working without any limitations.

7.7 DEVICE CONFIGURATION

Overview of the device configuraton levels:

There are 3 levels:

- Level 1: for operator
- Level 2: for WAGNER Service
- Level 3: for WAGNER production plant

7.7.1 PARAMETER OVERVIEW OF LEVEL 1 FOR USERS

Parameter	Value	Description
C11 External release (remote)	off (factory setting)	The device functions as a standalone device. External release by interface does not have to be defined. The bypass is activated.
	on	If parameter C11 is set, the LED "External release" on the control unit lights up continuously. The external release by interface must be issued. If the trigger is pulled despite the fact that no release has been issued, the LED display "External release" starts to flash quickly. Release is present when input is connected to GND.
C12 External set value specification	off (factory setting)	The set values for high-voltage in kV and current limitation in μ A are set at the operating panel.
	on	The set values for high-voltage in kV and current limitation in μ A are predefined using the interface's two analog power inputs. Application example: Set value specification by superordinate control (PLC) Set values can no longer be adjusted at the front control panel. All recipe functions (save, call up recipe, etc.) are locked.
C13 Lock	off (factory setting)	Lock is deactivated.
	on	Lock is activated, set values (kV and μ A) cannot be changed, user can only select recipes and control functions.
	pro	Lock pro (program) You can select recipes and control functions. The target values (kV and μ A) can be adjusted but cannot be saved in the recipes.

C14	Operation mode This parameter is linked to parameter C11. If parameter C14 is set, parameter C11 is automatically switched to "off".	off (factory setting)	Operation with GM 5000EA or GM 5000EAC manual spray gun
		2	Electrostatic automatic spray gun
		3	High-voltage Universal 3 G cascade
		4	High-voltage Universal 7.5 G cascade
C15	Lock of gun operating button	off (factory setting)	Lock is switched off.
		1	Partial lock of gun operating button: - Standby function disabled. - Recipe change is possible.
		2	Partial lock of gun operating button: - Recipe change disabled. - Standby is possible.
		3	Full lock of gun operating button: - Recipe change disabled. - Standby function disabled.
C19	Reset recipes	no (factory setting)	No reaction
		res	All programs are set to delivery condition, if "res" is saved with the "Service" button.
C20	Reset configuration	no (factory setting)	No reaction
		res	All configuration parameters are set to delivery condition (factory setting), if "res" is saved with the "Service" button.

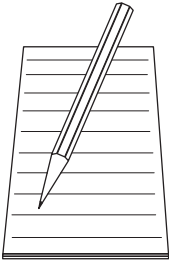

A series of horizontal lines for writing, starting from the top right of the page and extending downwards. The lines are evenly spaced and cover most of the page's width.

7.7.2 ACCESS TO THE DEVICE CONFIGURATION MODE

Procedure:

1. Switch to "Standby" by pressing the "Standby" button (17).
The orange LED "Standby" (18) lights up.

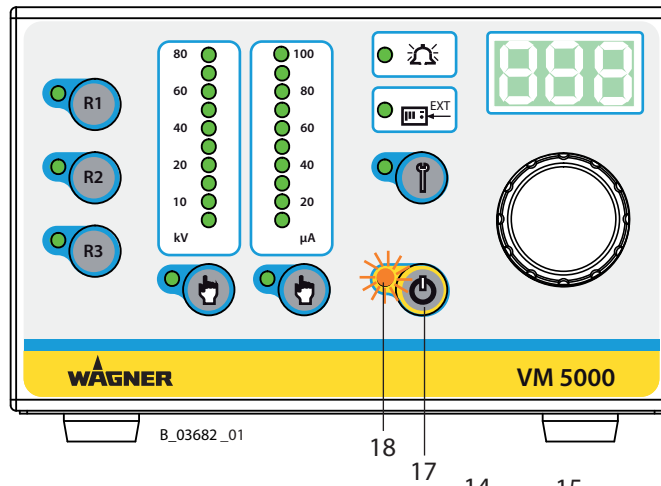

2. Press and hold the "Service" push button (14).
3. Turn the universal control dial (16) with the other hand until the display (15) shows the number "10".
Then release the "Service" button (14).
The scrolling text "Configuration" is displayed.
The device is now in configuration mode.

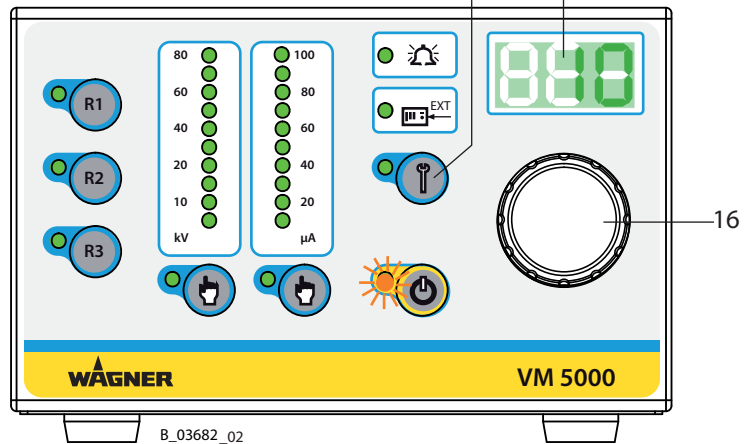

4. The LED display (15) now shows the first configuration setting C11.
At the same time, the two LED displays "High Voltage" (22) and "Spray Current Limitation" (20) start to flash.
The illuminated display "Standby" (18) flashes quickly.

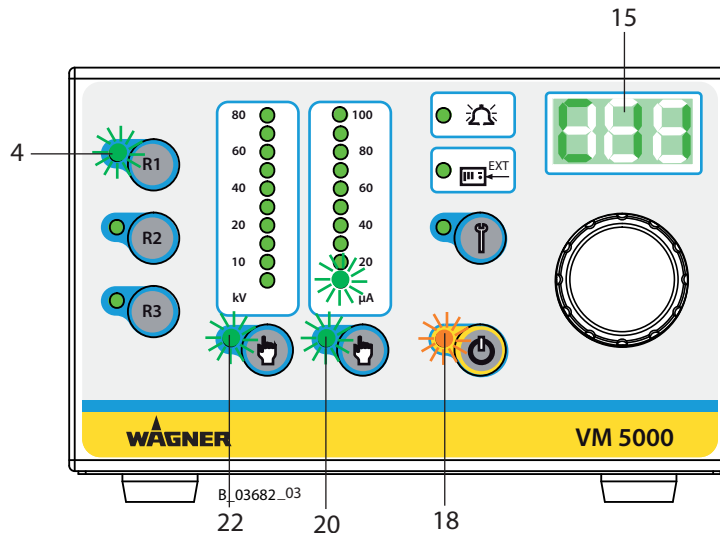

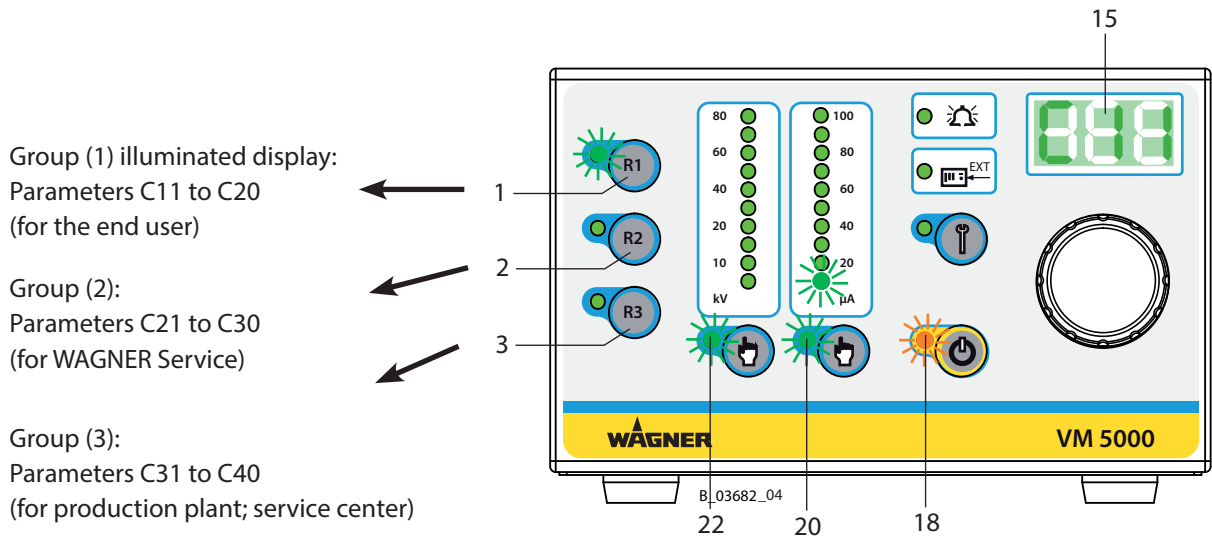

Group (1) illuminated display:
Parameters C11 to C20
(for the end user)

Group (2):
Parameters C21 to C30
(for WAGNER Service)

Group (3):
Parameters C31 to C40
(for production plant; service center)

For ease of operation the configuration settings are divided into three groups. The first group is for the end user, the other two groups are password protected and reserved for Wagner Service and the Wagner production sites or the Wagner Service Center, which have the necessary infrastructure.

7.7.3 SETTING EXAMPLE "PARAMETER C11"

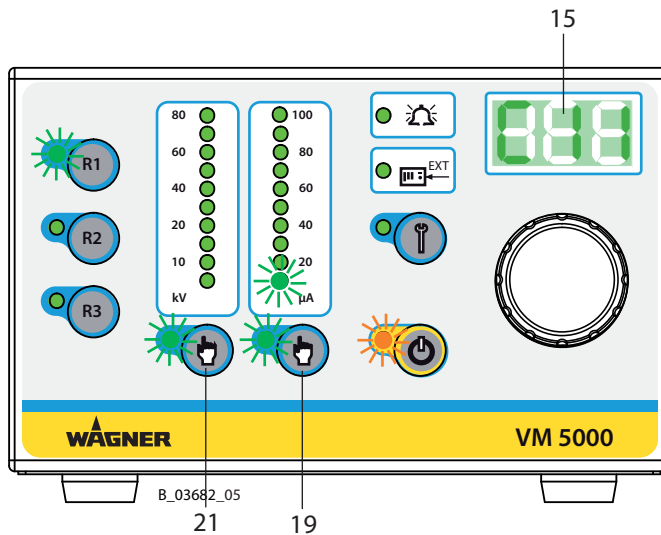

After getting started in configuration mode, the display (15) shows parameter "C11" by default.

Press one of the push buttons (21) or (19) to select all kinds of parameters for the end user. To change a selected parameter value (e.g. C11), press push key "Service" (14). The content of C11 is displayed (15).

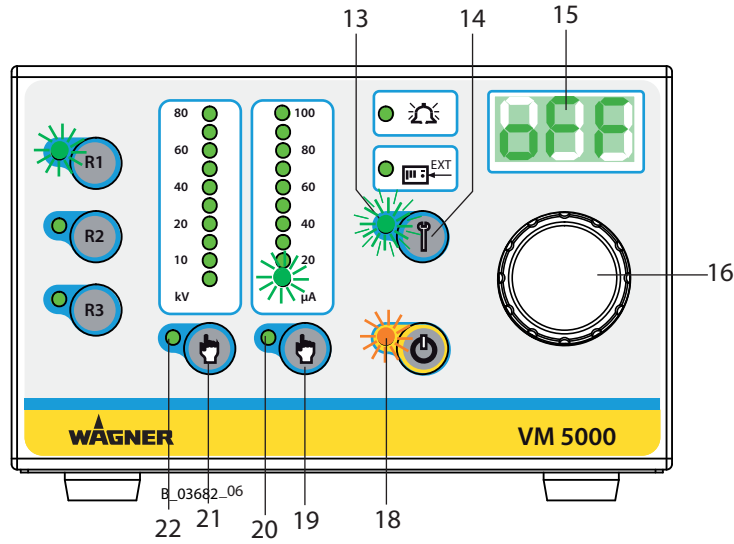

The flashing LED display (13) indicates that the parameter value "oFF" in the display (15) can be changed with the universal control dial (16). Possible values in C11 are "on" or "oFF". Press and hold the push button (14) to save the set value to C11. Once the value has been saved, the illuminated display (13) starts flashing quickly.

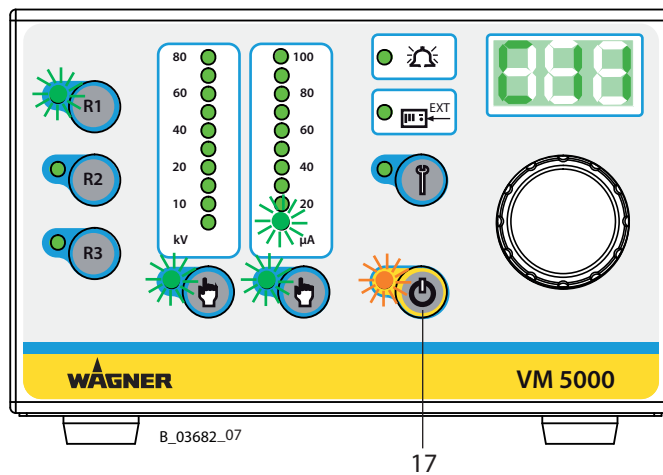

Going from the configuration mode back to the operating mode:
Press the "Standby" button (17).

7.8 OPERATING HOURS COUNTER/SERVICE DISPLAY

Two hour counters are integrated into the control unit. The absolute counter measures the ongoing hours of operation of the spray gun and maintenance intervals for the spray gun can therefore be determined and monitored with the maintenance hours counter.

When the control unit is in the ready position, you can access the maintenance menu screen using the push button (14).

Maintenance menu structure (illuminated display (13) is activated)

Push button	Description of display
R1	Display of the spray gun's absolute accrued operating hours. Display format: Counter reading < 999 hours: 001 = 1 h; 291 = 291 h Counter reading > 1,000 hours: 1.23 = 1,230 h; 45.2 = 45,200 h Maximum display value = 99.9 = 99900 hours Afterwards it shows flashing dashes.
R2	Display of temporary maintenance counter and how to reset this counter
R3	Set maintenance interval in hours activate or lock this function

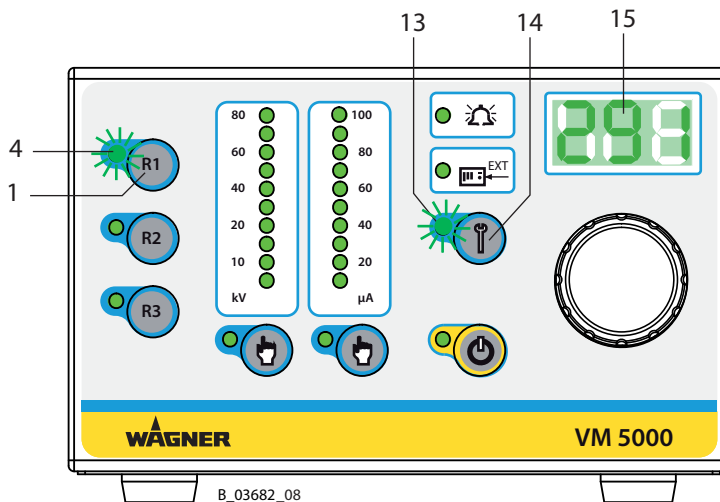

B_03682_08

7.8.1 MAINTENANCE COUNTER SET UP AND READING

When using the device for the first time, the function for the maintenance hours counter is deactivated. This function can be activated with the "R3" push button (3). The maintenance interval limit can be set within a range of 0 to 999 hours.

Setting and saving the service interval limit in hours

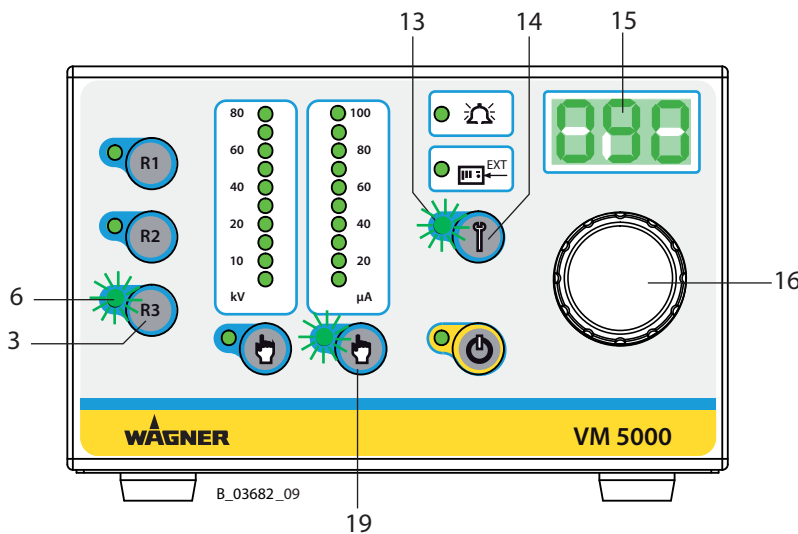

Procedure:

1. Press the push button (3) briefly. Illuminated display (6) lights up.
2. Use the control dial (16) to set the maintenance interval limit you want (e.g., 90 hours).
3. Check setting on the display (15).
4. To save the value, press the push button (19) and hold until the display (15) starts flashing quickly.

Review counter reading since last service carried out on the gun

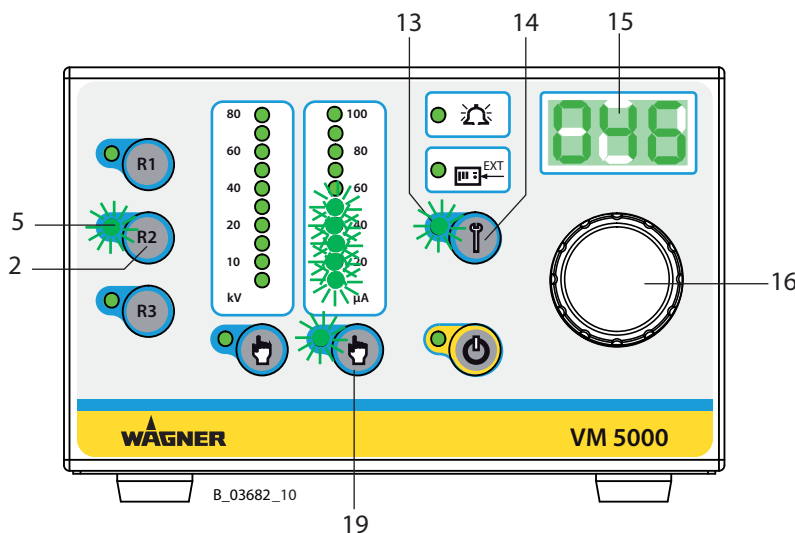

Procedure:

1. Press the push button (2) briefly. Illuminated display (5) lights up.
2. Read display (15). In the example, 46 hours have passed since realization of the last spray gun service. The vertical graph on the left indicates that 50% of the set interval time has passed.
3. By pressing and holding the push button (19), you can reset the display (15) to 0 (reset).

7.9 EXTERNAL INTERFACE

The control unit is equipped with an interface. Before using it, you have to select the respective parameters in the device configuration.

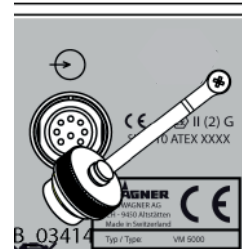

External release

GND >> Release
white

Fault reset
neg. edge >> Reset
brown

Fault output
24VDC >> Fault
green

HV input
8V >> 80kV
yellow

µA input
10 V >> 100 µA
gray

HV output
8V >> 80kV
pink

µA output
10 V >> 100 µA
blue

Ground
red

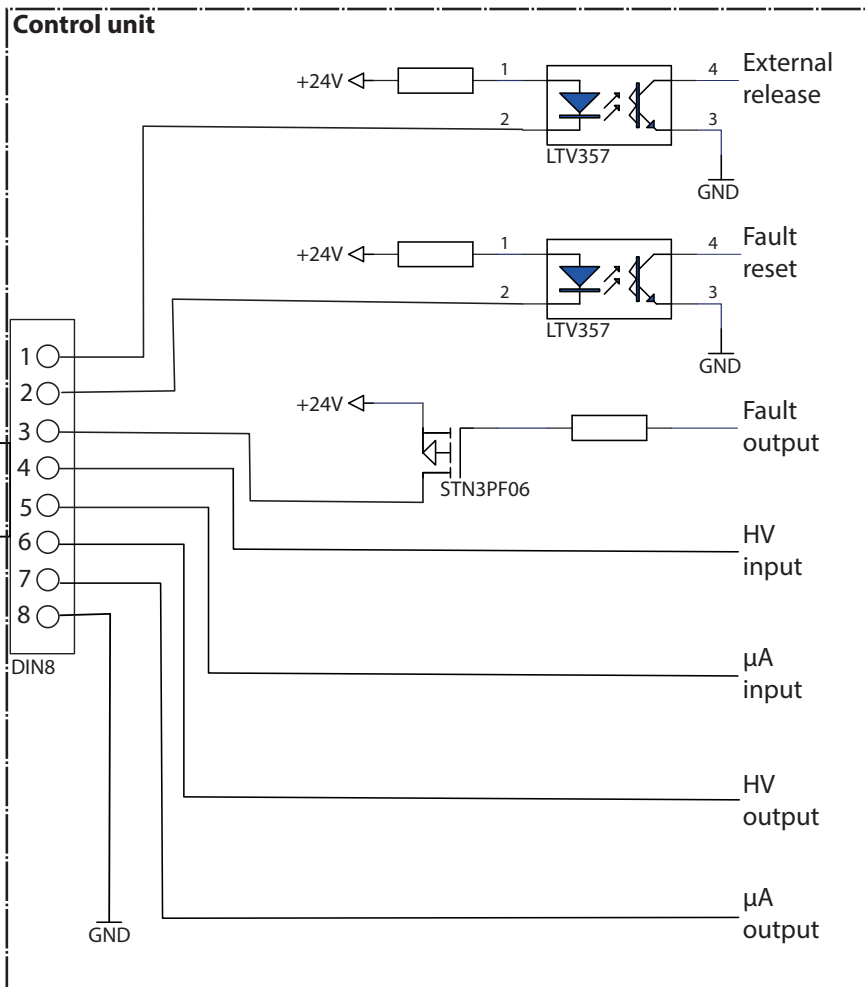

B_03415

Pin no.	Designation	Description
1 in	External release	Potential-free contact between pin 1 and pin 8 (ground) - Closed → Release issued - Open → Release not issued
2 in	Fault reset	Potential-free contact (button) between pin 2 and pin 8 (ground) - If there is a fault, it can be acknowledged by pressing a button. - Acknowledgement is only given via the negative edge.
3 out	Fault output	If there is a fault, +24VDC is issued at pin 3 in reference to pin 8 (ground). - Maximum current 0.5 A
4 in	DC kV in	Set value specification for high-voltage Analog DC current input between pin 4 in reference to pin 8 (ground) - 0.1V corresponds to 1kV - 8.0V is the maximum specification and corresponds to 80kV
5 in	DC µA in	Set value specification for spray current limitation Analog DC current input between pin 5 in reference to pin 8 (ground) - 0.1V corresponds to 1µA - 10.0V is the maximum specification and corresponds to 100µA
6 out	DC kV out	Output of current working voltage Analog DC current output between pin 6 in reference to pin 8 (ground) - 0.1V corresponds to 1kV - 8.0V is the maximum output and corresponds to 80kV
7 out	DC µA out	Output of current working spray current Analog DC current output between pin 7 in reference to pin 8 (ground) - 0.1V corresponds to 1µA - 10.0V is the maximum output and corresponds to 100µA

8 CLEANING AND MAINTENANCE

8.1 CLEANING

8.1.1 CLEANING STAFF



Cleaning work should be undertaken regularly and carefully by qualified and trained staff. They should be informed of specific hazards during their training.

The following hazards may arise during cleaning work:

- Use of unsuitable cleaning tools and aids

8.1.2 SAFETY INSTRUCTIONS

- Do not open the control unit.
- Observe safety instructions in Chapter 4.



	 DANGER
	<p>Incorrect maintenance/repair! Danger to life and damage to the device.</p> <ul style="list-style-type: none">→ Only a WAGNER service center or a suitably trained person may carry out repairs and replace parts.→ Only repair and replace parts that are listed in the "Spare Parts" chapter and that are assigned to the device.→ Before all work on the device and in the event of work interruptions:<ul style="list-style-type: none">- Switch off the energy/compressed air supply.- Relieve the pressure from the spray gun and device.- Secure the spray gun to prevent actuation.→ Observe the operating manual and service manuals at all times when carrying out work.



Cleaning the control unit

If there are deposits on the surfaces, the device may form electrostatic charges. Flames or sparks can form during discharge.

- Remove deposits from the surfaces to maintain conductivity.
- Only use a damp cloth to clean the device.



	 DANGER
	<p>Explosive powder/air mixes! Danger to life and damage to the device.</p> <ul style="list-style-type: none"> → Before starting the cleaning, de-energize the device. → Only electrically conductive tanks may be used for cleaning and flushing agents. Earth the tank. → Clean the control unit with non-flammable cleaning agent. → Ensure that no electric component is cleaned with or immersed into solvent.

	 WARNING
	<p>Incompatibility of cleaning/flushing agent and working medium! Risk of explosion and danger of poisoning by toxic gases</p> <ul style="list-style-type: none"> → Examine the compatibility of the cleaning and flushing agents and working media on the basis of the safety data sheets.

8.2 MAINTENANCE

8.2.1 MAINTENANCE STAFF

Maintenance work should be undertaken regularly and carefully by qualified and trained staff. They should be informed of specific hazards during their training.

The following hazards may arise during maintenance work:

- Use of unsuitable tools and aids

An authorized person must ensure that the device is checked for being in a reliable state after maintenance work is completed.

8.2.2 SAFETY INSTRUCTIONS

→ Observe the safety instructions in Chapter 4 and Chapter 8.1.2.

Prior to maintenance



- Flush and clean the system.



After maintenance

- Carry out a safety check in accordance with Chapter 8.2.3.
- Put the system into operation and check for leaks.

→ In accordance with the guideline for liquid ejection devices (ZH 1/406 and BGR 500 Part 2 Chapter 2.29 and Chapter 2.36):

- The liquid ejection devices should be checked by an expert (e.g. WAGNER service technician) to ensure their safe operational condition as required and at least every 12 months.
- If devices have been decommissioned, the examination can be suspended until the next start-up.

	 DANGER
	<p>Incorrect maintenance/repair! Danger to life and damage to the device.</p> <p>→ Repair or replacement of devices or parts of devices are only allowed to be performed outside the hazard area by qualified personnel.</p>



	 DANGER
	<p>Incorrect maintenance/repair! Danger to life and damage to the device.</p> <ul style="list-style-type: none"> → Only a WAGNER service center or a suitably trained person may carry out repairs and replace parts. → Only repair and replace parts that are listed in the "Spare Parts" chapter and that are assigned to the device. → Before all work on the device and in the event of work interruptions: <ul style="list-style-type: none"> - Switch off the energy/compressed air supply. - Relieve the pressure from the spray gun and device. - Secure the spray gun to prevent actuation. → Observe the operating manual and service manuals at all times when carrying out work.

8.2.3 SAFETY CHECKS

The functionality and completeness of the control unit must be checked regularly. All sealed elements on the control unit must be present and undamaged. During operation, all electric connections of the control unit have to be tightly sealed with the corresponding plug connectors or closing elements.

Leak test

The leakage tightness of the device has to be checked at least every 3 years. The "Restricted breathing" requirements according to DIN EN 60079-15:2011 have to be fulfilled. This inspection may only be carried out by a skilled person or by trained WAGNER service personnel. When carrying out the leakage tightness test, the mains input terminal serves as a test port.

	 WARNING
	<p>Sparks form when live components are separated or connected! Explosion hazard from electric sparks.</p> <ul style="list-style-type: none"> → Do not disconnect plug connections under voltage. → Do not open fuse holders under voltage. → Do not remove the service plug cover under voltage.

9 TROUBLESHOOTING AND RECTIFICATION

Functional fault	Cause	Remedy
No illuminated display lights up	<ul style="list-style-type: none"> - Mains supply not switched on. - Fuses defective 	<ul style="list-style-type: none"> - Check and switch on mains supply - Replace fuses - Wagner Service
No high-voltage	<ul style="list-style-type: none"> - Spray gun cable not connected or defective - Spray gun not connected or defective - Excessive conductivity of the lacquer 	<ul style="list-style-type: none"> - Connect spray gun cable - Wagner Service - See operating manual of spray gun
Malfunction LED (12) lights up. Fault message in display (15)	<ul style="list-style-type: none"> - See the following table 	<ul style="list-style-type: none"> - See the following table

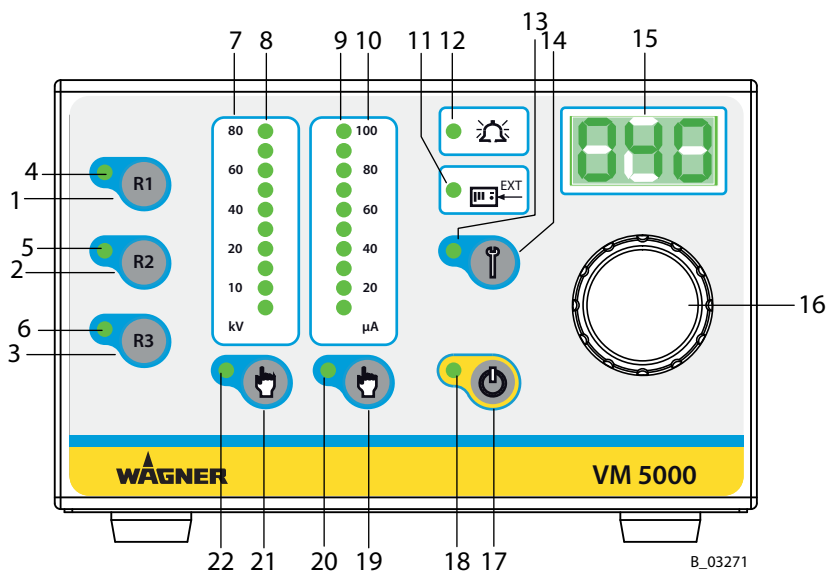

The fault LED (12) indicates faults. In addition, the error number is shown in the 7-segment display (15). If a fault occurs, the high voltage is immediately switched off. The user can only continue to work once the fault has been remedied and acknowledged with push button for service (14).

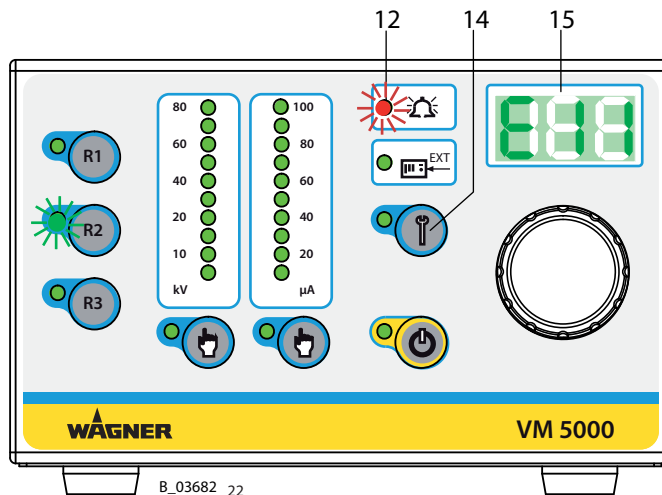

Code display	Fault	Cause	Remedy
E11	Ground monitoring	<ul style="list-style-type: none"> - Grounding cable is interrupted - Gun is not connected 	<ul style="list-style-type: none"> - Check/replace gun cable - Check/replace gun - Connect gun
E12	No coil current/ cascade interrupt	<ul style="list-style-type: none"> - Gun is not connected - Gun cable is interrupted - Cascade in gun is interrupted → defective 	<ul style="list-style-type: none"> - Connect gun - Check/replace gun cable - Check/replace gun
E13	Coil current too big	<ul style="list-style-type: none"> - Cascade of the connected gun is defective 	<ul style="list-style-type: none"> - Check/replace gun
E21-E29	Exception error	<ul style="list-style-type: none"> - Hardware defect has occurred 	<ul style="list-style-type: none"> - If problem persists, contact the WAGNER Service Team
E30	Cabinet door monitoring	<ul style="list-style-type: none"> - In Aquacoat operation: switching on the high-voltage with an open door 	<ul style="list-style-type: none"> - Close Aquacoat cabinet door
E40-E43	Gun communication faulty	<ul style="list-style-type: none"> - Gun cable defective - Operating unit of spray gun defective - Control unit defective 	<ul style="list-style-type: none"> - Check/replace gun cable - Wagner Service - Wagner Service
E60	Password error	<ul style="list-style-type: none"> - Password not set 	<ul style="list-style-type: none"> - Password to be set by Service Center

10 REPAIR WORK

10.1 REPAIR STAFF

Repair work must be carried out carefully by qualified and trained staff. They should be informed of specific hazards during their training.

The following hazards may arise during repair work:

- Use of unsuitable tools and aids

A skilled person must ensure that the device is checked for being in a reliable state after repair work is completed.



10.2 SAFETY INSTRUCTIONS

→ Observe the safety instructions in Chapter 4 and Chapter 8.1.2.

Before repair: Flush and clean the system.

After repair work



- Check leak-tightness of control unit as described in Chapter 10.3.
 - Carry out a safety check in accordance with Chapter 8.2.3.
 - Put the system into operation and check for leaks.
- In accordance with the guideline for liquid ejection devices (ZH 1/406 and BGR 500 Part 2 Chapter 2.29 and Chapter 2.36):
- The liquid ejection devices should be checked by an expert (e.g. WAGNER service technician) to ensure their safe operational condition as required and at least every 12 months.
 - If devices have been decommissioned, the examination can be suspended until the next start-up.

	 WARNING
	<p>Sparks form when live components are separated or connected! Explosion hazard from electric sparks.</p> <ul style="list-style-type: none"> → Do not disconnect plug connections under voltage. → Do not open fuse holders under voltage. → Do not remove the service plug cover under voltage.

10.3 CHECK THE CONTROL UNIT FOR LEAK-TIGHTNESS

The "Restricted breathing" requirements according to DIN EN 60079-15:2011 have to be fulfilled. When carrying out the leakage tightness test, the mains input terminal serves as a test port.

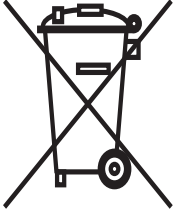
11 DISPOSAL

 	<p style="text-align: center;">NOTICE</p> <p>Do not dispose of used electrical equipment with household refuse!</p> <p>In accordance with European Directive 2002/96/EC on the disposal of used electrical equipment and its implementation in national law, this product may not be disposed of with the household refuse, but must be recycled in an environmentally correct manner.</p> <p>WAGNER or one of our dealers will take back your used WAGNER electric or electronic equipment and will dispose of it for you in an environmentally-friendly manner. Please contact one of our service points, one of our representatives or us directly to arrange this.</p>
--	--

Consumable products

Consumable products (lacquers, adhesives, flushing and cleaning agents) must be disposed of in accordance with all applicable legal requirements.

12 ACCESSORIES

Order No.	Designation	
241270	Mains cable Europe 3 m; 9.8 ft	 B_01065
2330628	Mains cable Europe 10 m; 32.8 ft	
241271	Mains cable Switzerland 3 m; 9.8 ft	
264626	Mains cable USA 2 m; 6.6 ft	
264625	Mains cable Japan 3 m; 9.8 ft	
2317600	Interface cable VM 5000, 10 m; 32.8 ft	 B_03471
130215	Grounding cable 10 m; 32.8 ft	 B_01063
264332	Grounding cable, complete 0.75 m; 2.5 ft	 B_01064
2327509	Mounting control unit, complete	 B_03735

Hose sets and spray gun cable

→ See operating manual of spray gun.

13 SPARE PARTS

13.1 HOW CAN SPARE PARTS BE ORDERED?

Always supply the following information to ensure delivery of the right spare part:

Order number, designation, and quantity

The quantity need not be the same as the number given in the quantity column "**Stk**" on the lists. This number merely indicates how many of the respective parts are used in each component.

The following information is also required to ensure smooth processing of your order:

- Billing address
- Delivery address
- Name of the person to be contacted in the event of any queries
- Type of delivery (normal mail, express delivery, air freight, courier etc.)

Identification in spare parts lists

Explanation of column "**K**" (labeling) in the following spare parts lists:

- ◆ Wearing parts

Note: These parts are not covered by warranty terms.

- Not part of the standard equipment but available as a special accessory.



DANGER

Incorrect maintenance/repair!

Danger to life and **damage to the device.**

- Only a WAGNER service center or a suitably trained person may carry out repairs and replace parts.
- Only repair and replace parts that are listed in the "Spare Parts" chapter and that are assigned to the device.
- Before all work on the device and in the event of work interruptions:
 - Switch off the energy/compressed air supply.
 - Relieve the pressure from the spray gun and device.
 - Secure the spray gun to prevent actuation.
- Observe the operating manual and service manuals at all times when carrying out work.

13.2 CONTROL UNIT VM 5000

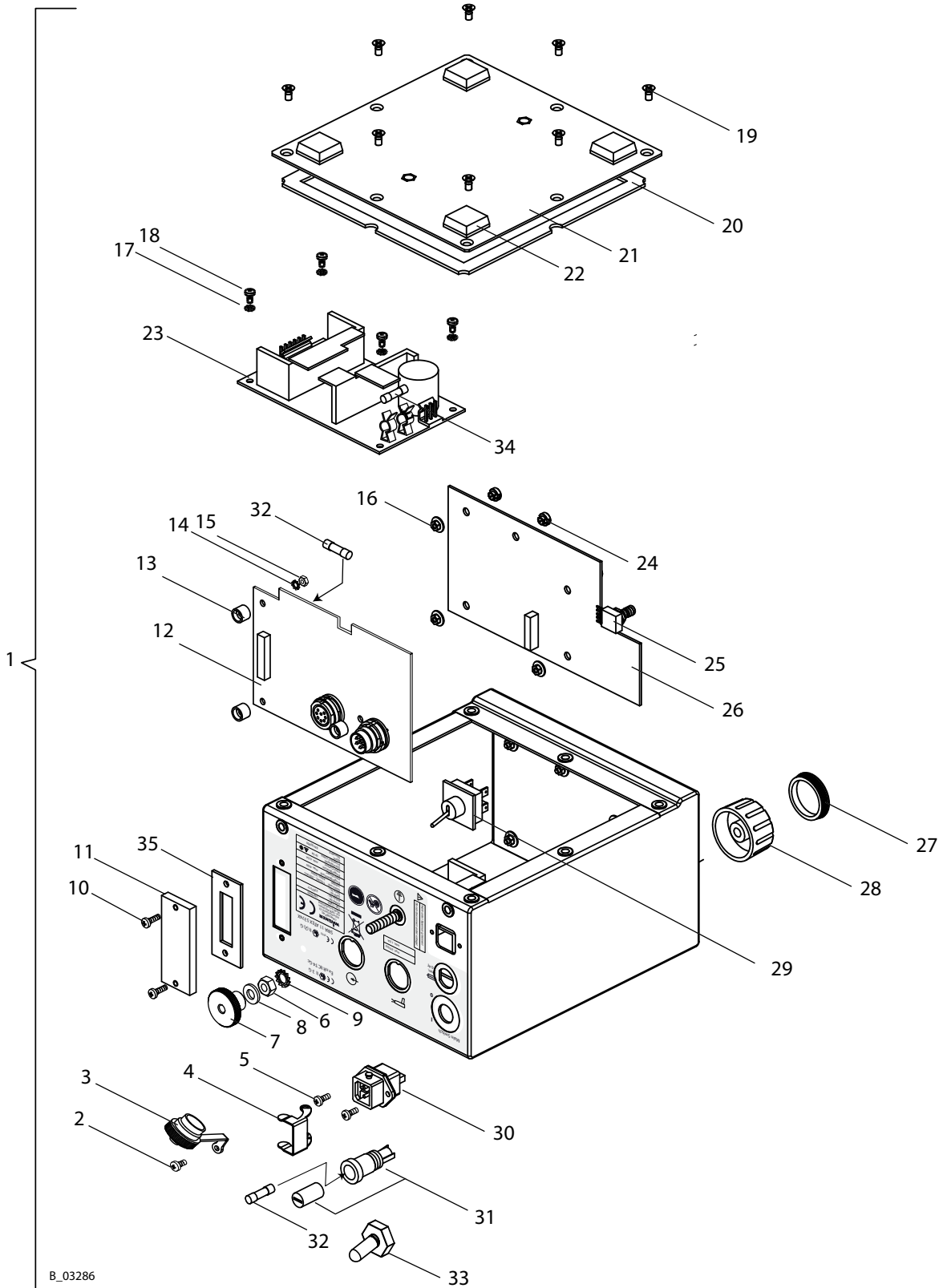

B_03286

Spare parts list for VM 5000 control unit

Pos	Stk	Order No.	Designation
1	1	2310477	VM 5000 control unit
2	1	9903312	Recessed head raised fillister head screw, H form
3	1	9952593	Protection cap for device socket
4	1	9950330	Safety clip for device sockets
5	2	9903306	Recessed head raised fillister head screw, H form
6	1	9910102	Hexagon nut
7	1	9910522	High knurled nut
8	1	9920118	Washer
9	1	9922017	Serrated lock washer, externally toothed
10	2	9903311	Recessed head raised fillister head screw, H form
11	1	241323	Cover, white
12	1	2317538	Print VM 5000 rear panel, complete (ET)
13	3	263400	Distance bush
14	3	9922011	Serrated lock washer, externally toothed
15	3	9910103	Hexagon nut
16	5	2312348	Hexagon lock nut
17	4	9922011	Serrated lock washer, externally toothed
18	4	9903312	Recessed head raised fillister head screw, H form
19	8	2306405	Recessed countersunk flat head screw, Z form
20	1	2307315	Seal
21	1	2307309	Cover
22	4	9990839	Buffer
23	1	9955176	Switching power supply
24	5	2309112	Spacer
25	1	2311875	Incremental encoder
26	1	2317539	Print complete VM 5000 display (with position 25)
27	1	2304462	Cover
28	1	2304461	Rotary knob
29	1	9953536	2-pin toggle switch
30	1	9952587	Connector plug
31	1	9955021	Fuse socket
32	2	9951117	Delay-action fuse 1.0 AT
33	1	9971519	Rubber seal
34	1	9955601	Fast-acting fuse, 2.5 A
35	1	2325264	Seal

14 WARRANTY AND CONFORMITY DECLARATIONS

14.1 IMPORTANT NOTES REGARDING PRODUCT LIABILITY

As a result of an EC regulation effective from January 1, 1990, the manufacturer shall only be liable for his product if all parts originate from him or are approved by him, and if the devices are properly mounted, operated and maintained.

The manufacturer will not be held liable or will only be held partially liable if third-party accessories or spare parts have been used.

With genuine WAGNER accessories and spare parts, you have the guarantee that all safety regulations are complied with.

14.2 WARRANTY CLAIM

Full warranty is provided for this device:

We will at our discretion repair or replace free of charge all parts which within 24 months in single-shift, 12 months in 2-shift or 6 months in 3-shift operation from date of receipt by the purchaser are found to be wholly or substantially unusable due to causes prior to the sale, in particular faulty design, defective materials or poor workmanship.

The type of warranty provided is such that the device or individual components of the device are either replaced or repaired as we see fit. The resulting costs, in particular shipping charges, road tolls, labor and material costs will be borne by us except where these costs are increased due to the subsequent shipment of the device to a location other than the address of the purchaser.

We do not provide warranty for damage that has been caused or contributed to for the following reasons:

Unsuitable or improper use, faulty assembly or commissioning by the purchaser or a third party, normal wear, negligent handling, defective maintenance, unsuitable coating products, substitute products and the influence of chemical, electrochemical or electrical agents, except when the damage is attributable to us.

Abrasive coating products such as red lead, emulsions, glazes, liquid abrasives, zinc dust paints and so forth reduce the service life of valves, packings, spray guns, nozzles, cylinders, pistons etc. Signs of wear traced back to these products are not covered by this warranty. Components that have not been manufactured by WAGNER are subject to the original warranty of the manufacturer.

Replacement of a component does not extend the period of warranty of the device.

The device should be inspected immediately upon receipt. To avoid losing the warranty, we or the supplier company are to be informed in writing about obvious faults within 14 days upon receipt of the device.

We reserve the right to have the warranty compliance met by a contracting company.

The services provided by this warranty are dependent on evidence being provided in the form of an invoice or delivery note. If the examination discovers that no warranty claim exists, the costs of repairs are charged to the purchaser.

It is clearly stipulated that this warranty claim does not represent any constraint on statutory regulations or regulations agreed to contractually in our general terms and conditions.

J. Wagner AG

14.3 CE DECLARATION OF CONFORMITY

CE declaration of conformity as defined by Atex-directive 94/9/EC.
Herewith we declare that the supplied version of

Electrostatic manual spraying system			
VM 500	VM 5000	GM 5000EA	GM5000EAC



complies with the following guidelines:

94/9/EC	2004/108/EC	2002/96/EC
2006/42/EC	2002/95/EC	

Applied standards, in particular:

DIN EN 50050:2007	DIN EN 61000-6-2:2006	DIN EN ISO 12100:2011
DIN EN 1953:2010	DIN EN 61000-6-4:2011	DIN EN 60079-0: 2010
DIN EN 60079-15: 2011	DIN EN 60204-1: 2007	

Applied national technical standards and specifications, in particular:

BGI 764

EC type approval certificate:

SIRA 11 ATEX 5374X issued by SIRA Certification, CH4 9JN, Chester, England, notified body no. 0518

Identification:

Control unit

CE₀₁₀₂ II (2) G
SIRA 11 ATEX 5374X

CE II 3 G Ex nR IIA T4 Gc

Spray gun:

CE₀₁₀₂ II 2 G EEx 0.24mJ
SIRA 11 ATEX 5374X

CE Certificate of Conformity

The CE certificate of conformity is enclosed with this product. If needed, further copies can be ordered through your WAGNER dealer by specifying the product name and serial number.

Order number:

2310487

14.4 NOTES ON NATIONAL REGULATIONS AND GUIDELINES

- a) TRBS 2131 Technical rule for operating safety
- b) BGR 500 Part 2, Chapter 2.36 Working with Liquid Ejection Devices
- c) BGR 500 Part 2, Chapter 2.29 Working with Coating Products
- d) TRBS 2153 Avoiding ignition risks
- e) BGR 180 Equipment for cleaning work pieces with solvents
- f) ZH 1/406 Guidelines for liquid ejection devices
- g) BGI 740 Painting rooms and equipment
- h) BGI 764 Electrostatic coating
- i) BetrSichV Plant Safety Ordinance

Note: All titles can be ordered from Heymanns Publishing House in Cologne, or they can be found on the Internet.

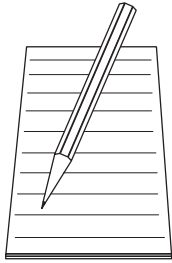

A series of horizontal lines for writing, starting from the top right of the notepad icon and extending across the width of the page. The lines are evenly spaced and cover most of the page's vertical space.

EDITION 08/2014

ORDER NUMBER DOC2318718

VM 5000

OPERATING MANUAL

WAGNER

WAGNER



Order No. 2318718
Edition 08/2014

Germany

J. WAGNER GmbH
Otto-Lilienthal-Str. 18
Postfach 1120

D- 88677 Markdorf

Phone +49/ (0)7544 / 5050

Fax +49/ (0)7544 / 505200

E-mail service.standard@wagner-group.com

Switzerland

J. WAGNER AG
Industriestrasse 22
Postfach 663

CH- 9450 Altstätten

Phone +41/ (0)71 / 757 2211

Fax +41/ (0)71 / 757 2222

More contact addresses on the internet at:

www.wagner-group.com

Company/Locations/WAGNER worldwide

Subject to changes without notice